

# 304 149 600 001 / 304 153 600 001

**ATTENTION : (pour connaître les caractéristiques d'utilisation consulter la carte grise).**

Installé suivant nos recommandations, cet attelage vous donnera entière satisfaction. Nous dégageons toute responsabilité en cas de transformation ou d'utilisation illicite de celui-ci

**FR**

**ACHTUNG: (Nutzungsmerkmale : siehe Fahrzeugschein)**

Diese Anhängervorrichtung wird Sie voll zufrieden stellen, wenn Sie unsere Montageanleitung befolgen. Im Falle der unerlaubten Veränderung oder des unerlaubten Gebrauchs lehnen wir jede Haftung ab.

**DE**

**PLEASE NOTE : (to familiarise yourself with the operating characteristics refer to the log).**

If this tow bar is fitted in accordance with our recommendations it will give a completely satisfaction. We cannot accept any responsibility in the event of changes to or improper use of this item.

**EN**

**BEMÆRK : (for yderligere oplysninger om anvendelsesforhold henvises der til registreringsattesten)**

Hvis dette anhængertræk monteres i henhold til vores anvisninger, vil det være til din fulde tilfredshed. Vi fralægger os ethvert ansvar ved ulovlig ændring eller brug af anhængertrækket.

**DA**

**ΠΡΟΣΟΧΗ : (για να πληροφορηθείτε τα χαρακτηριστικά χρήσης συμβουλευτείτε την γκριζα κάρτα)**

Εγκατεστημένο σύμφωνα με τις συστάσεις μας, αυτό το σύστημα ρυμούλκησης θα σας ικανοποιήσει πλήρως. Απεκδύομεθα πάσης ευθύνης σε περίπτωση μετατροπής ή παράνομης χρήσης αυτού.

**EL**

**ATENCIÓN: (para conocer las características de utilización, consultar el permiso de circulación)**

Instalado siguiendo nuestras recomendaciones, este enganche le dará total satisfacción. No asumiremos ninguna responsabilidad en caso de que haya sido transformado o utilizado ilícitamente.

**ES**

**UWAGA (charakterystyki użytkowania należy sprawdzić w dowodzie rejestracyjnym)**

Dyszel holowniczy będzie funkcjonował we właściwy sposób po zainstalowaniu go zgodnie z zaleceniami. Nie ponosimy żadnej odpowiedzialności w przypadku wprowadzenia zmian lub niedozwolonego użycia

**PL**

**HUOMIO: (käyttöominaisuuksiin tutustumiseksi on katsottava rekisteriotetta)**

Suosittelun mukaan asennettuna tämä vetokoukku täyttää odotuksesi.

Emme ota vastuuta, jos laitetta muutetaan tai käytetään ohjeiden vastaisesti.

**FI**

**ATTENZIONE : (per conoscere le caratteristiche d'uso consultare il libretto di ircolazione)**

Installato seguendo le nostre raccomandazioni, questo gancio da traino vi lascerà completamente soddisfatti. Respingiamo ogni responsabilità in caso di trasformazione o utilizzo illecito dello stesso.

**IT**

**LET OP : (voor gebruikkenmerken het kentekenbewijs raadplegen)**

Indien u de koppeling volgens onze aanbevelingen heeft geïnstalleerd, zal het u tot volle tevredenheid stemmen. Wij stellen ons niet aansprakelijk in geval van wijziging of onrechtmatig gebruik.

**NL**

**ADVARSEL: (for kunnskap om bruksegenskapene, se vognkortet)**

Ved å installere innretningen i samsvar med våre anbefalinger vil du få maksimalt utbytte av dette tilhengerfestet. Vi fraskriver oss alt ansvar hvis tilhengerfestet endres eller brukes på ulovlig måte.

**NO**

**POZOR: (užívateľské charakteristiky naleznete v technickém průkazu)**

Tažné zařízení instalované dle našich doporučení vás plně uspokojí. V případě přestavby nebo neoprávněného užívání se zbavujeme veškeré odpovědnosti

**CZ**

**VARNING: (Läs igenom registreringsbeviset för att ta reda på rådande användningsvillkor)**

Om du monterar produkten enligt våra anvisningar kommer du uppnå bästa möjliga resultat. Vi avsäger oss allt ansvar i de fall kunden inte följt våra anvisningar fullt ut.

**SV**

**304153600001 (SI 205)**  
**304149600001 (SI 206)**

DS5

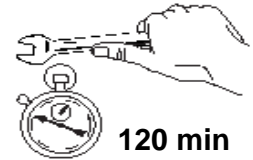
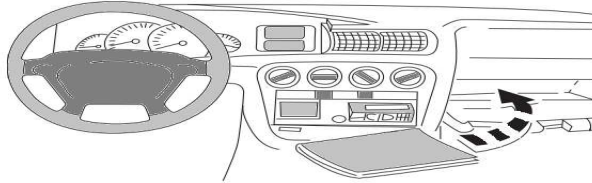
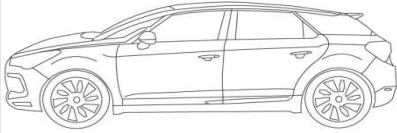

8,65 KN



SI 205  
e24\*55R\*01 0323  
SI 206  
e24\*55R\*01 0324



1500 Kg



75 kg

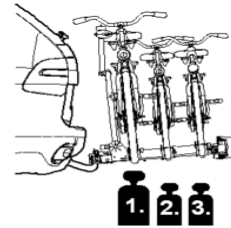

3 MAXI  
60 Kg MAXI



30 Kg MAXI

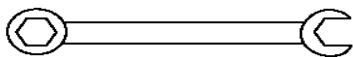
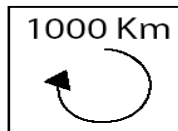
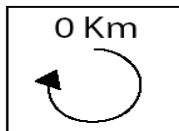

REF. WESTFALIA : 350030600001  
REF. SIARR : 8570

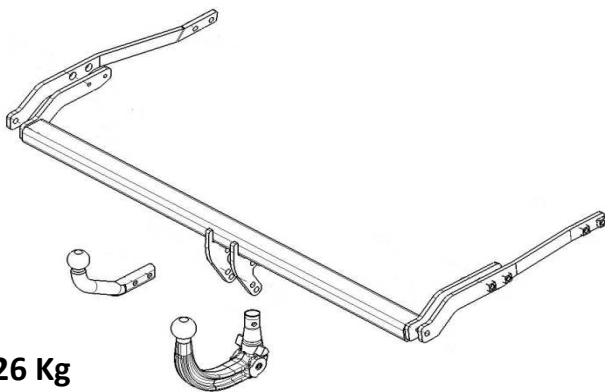

26 Kg



29 Kg



16 - 17 - 18 - 19





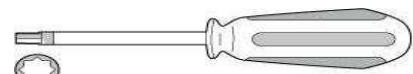

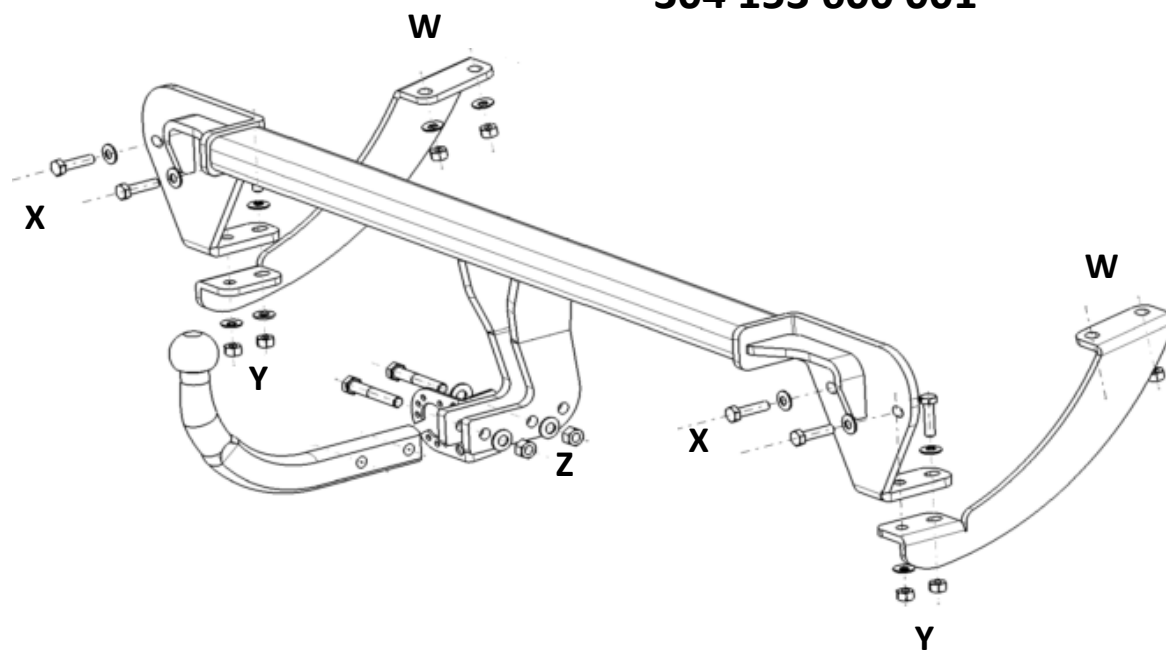

16 - 17 - 18 - 19









304 153 600 001



<b>X</b>	 HM 10 x 40 Cl 8.8	4
		



<b>Y</b>	 HM 10 x 40 Cl 8.8	4
	 CS 10	4
	 L 10 / 22	2
		



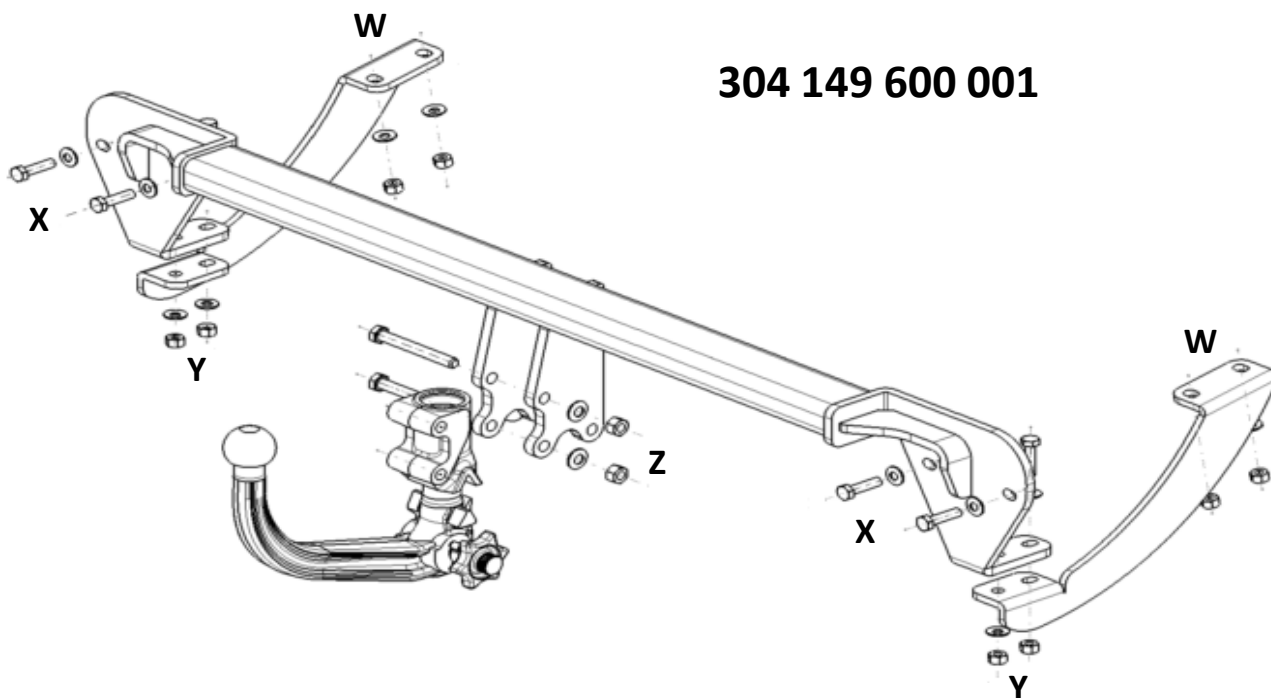

<b>W</b>	 M10 Cl8	4
	 CS 10	4



<b>Z</b>	 HM 12 x 75 Cl 10.9	2
	 CS 12	2
	 M12 Cl 10	2
	 L 12 / 27	1

304 149 600 001



<b>X</b>	 HM 10 x 40 Cl 8.8	4
		

<b>Y</b>	 HM 10 x 40 Cl 8.8	4
	 CS 10	4
	 L 10 / 22	2
	 M 10 Cl 8	4

<b>Z</b>	 HM 12 x 100 Cl 10.9	2
	 M12 Cl10	2
	 CS 12	2

<b>W</b>	 M 10 Cl 8	2
	 CS 10	2

01

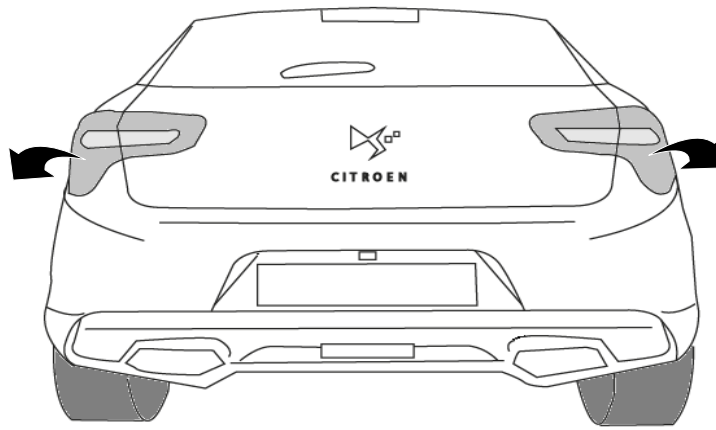

02

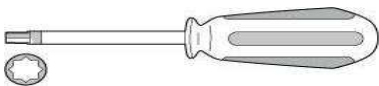
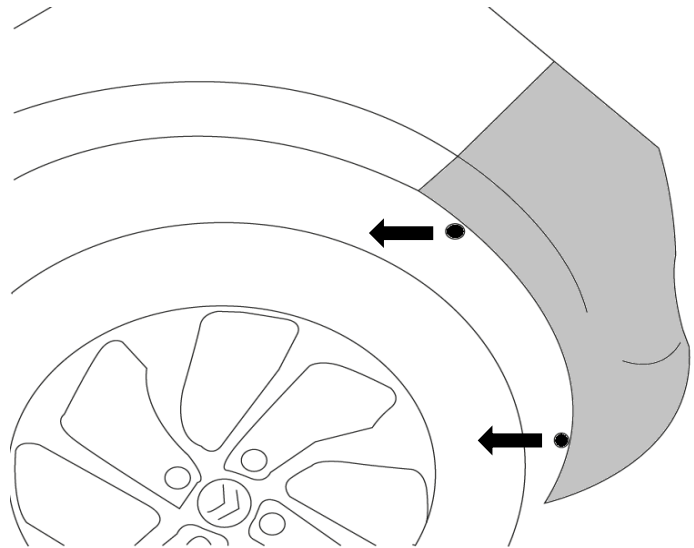

03

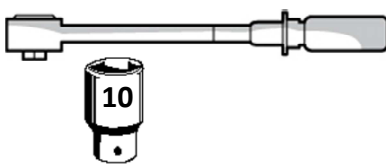
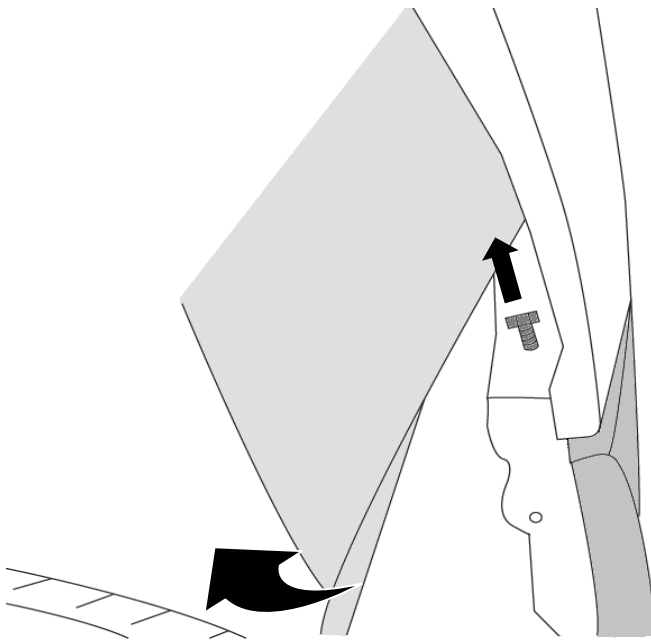

04

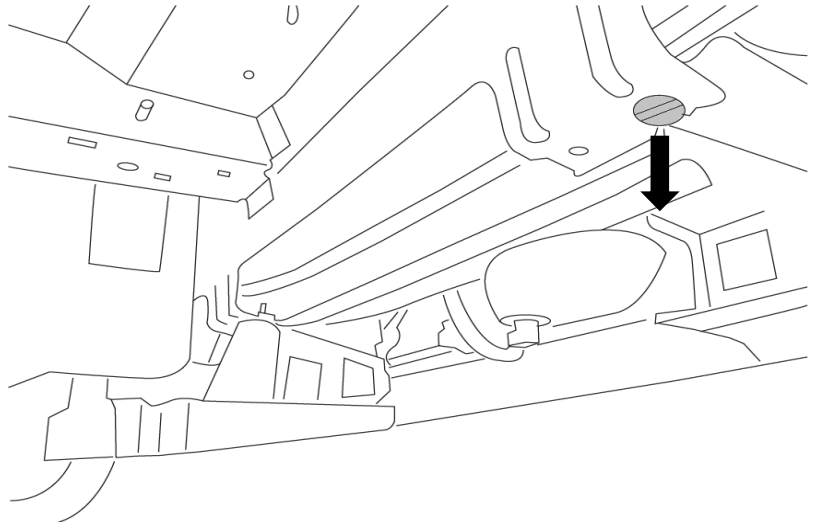
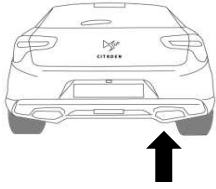

05

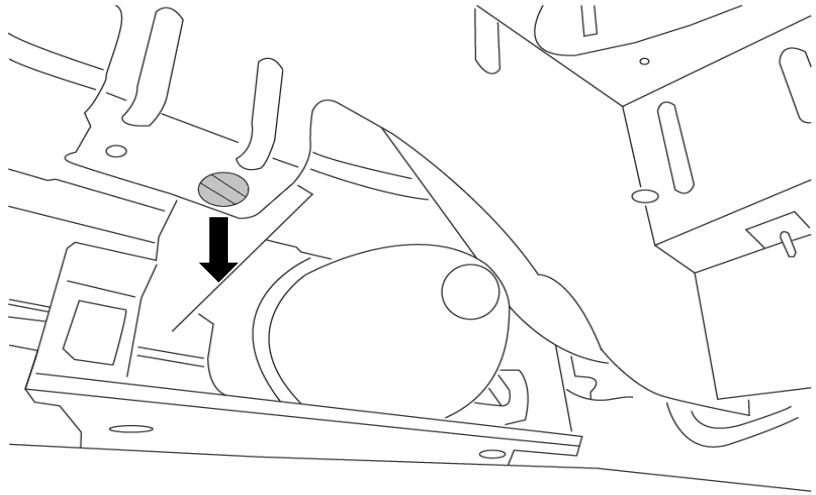
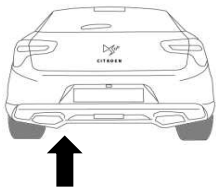

06

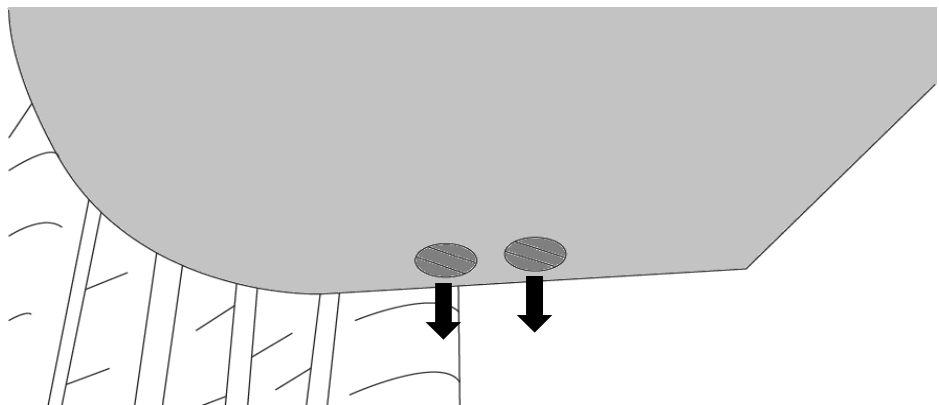
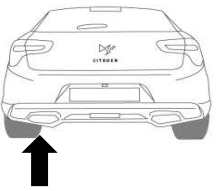

07

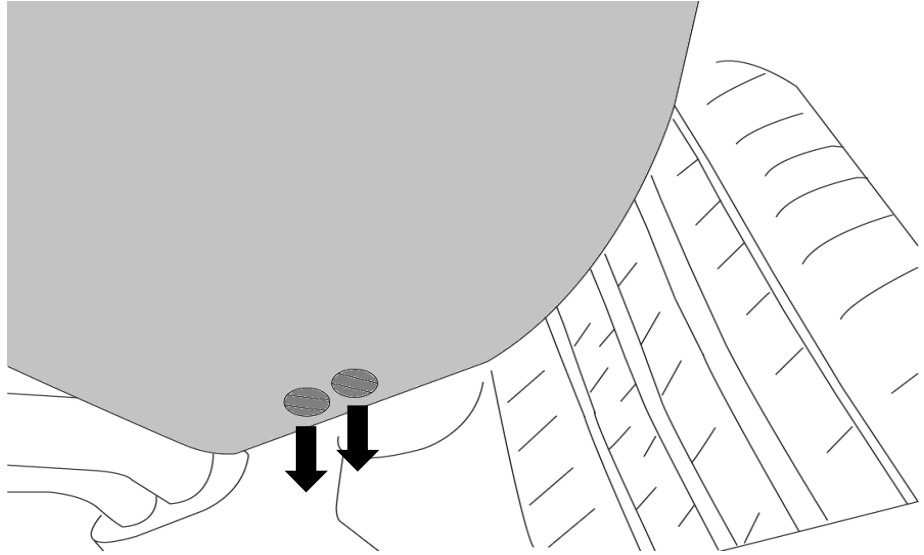
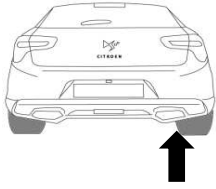

08

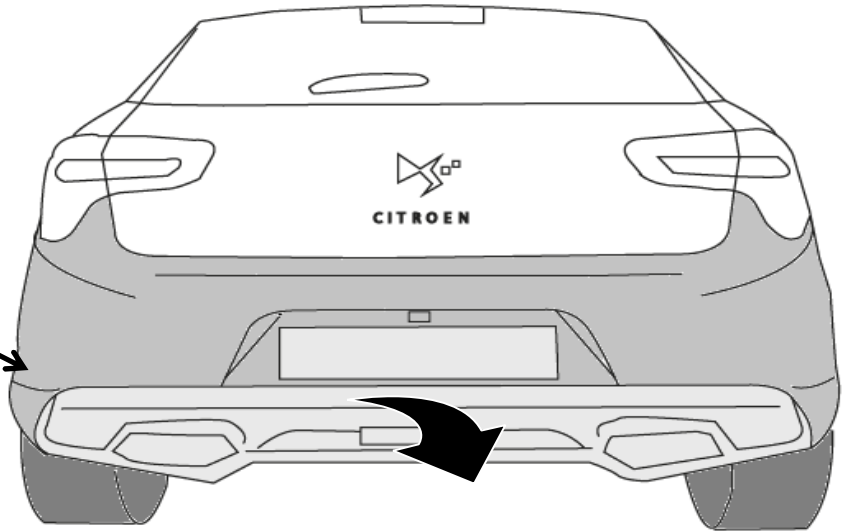
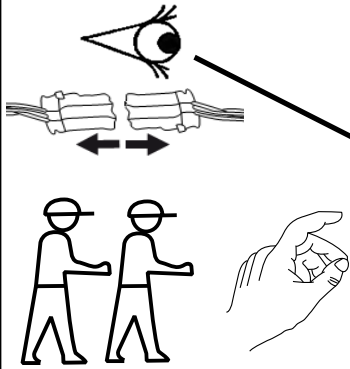

09

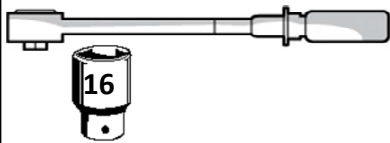
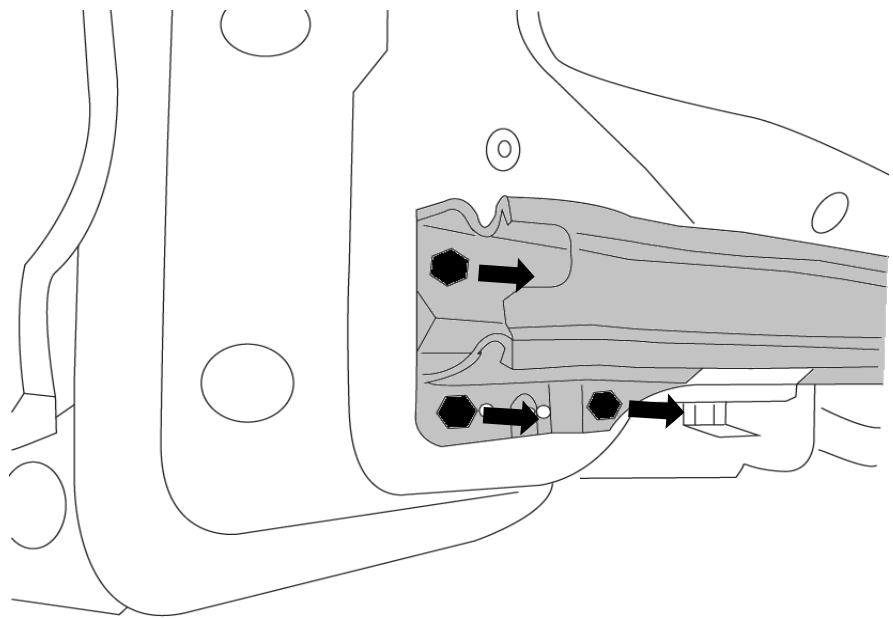
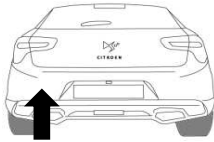

10

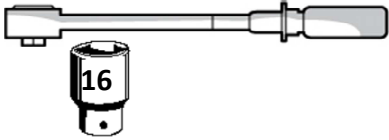
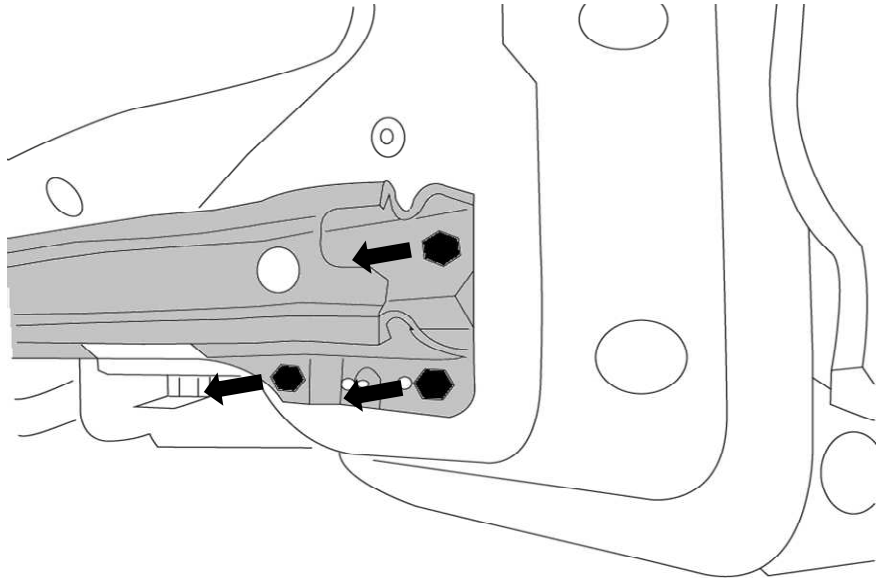
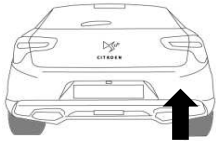

11

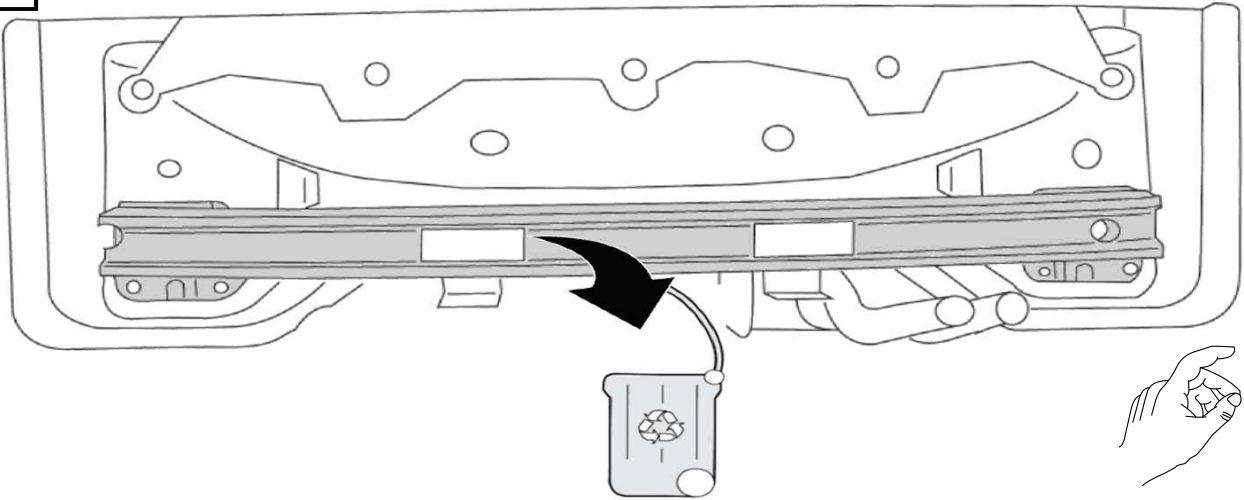

12

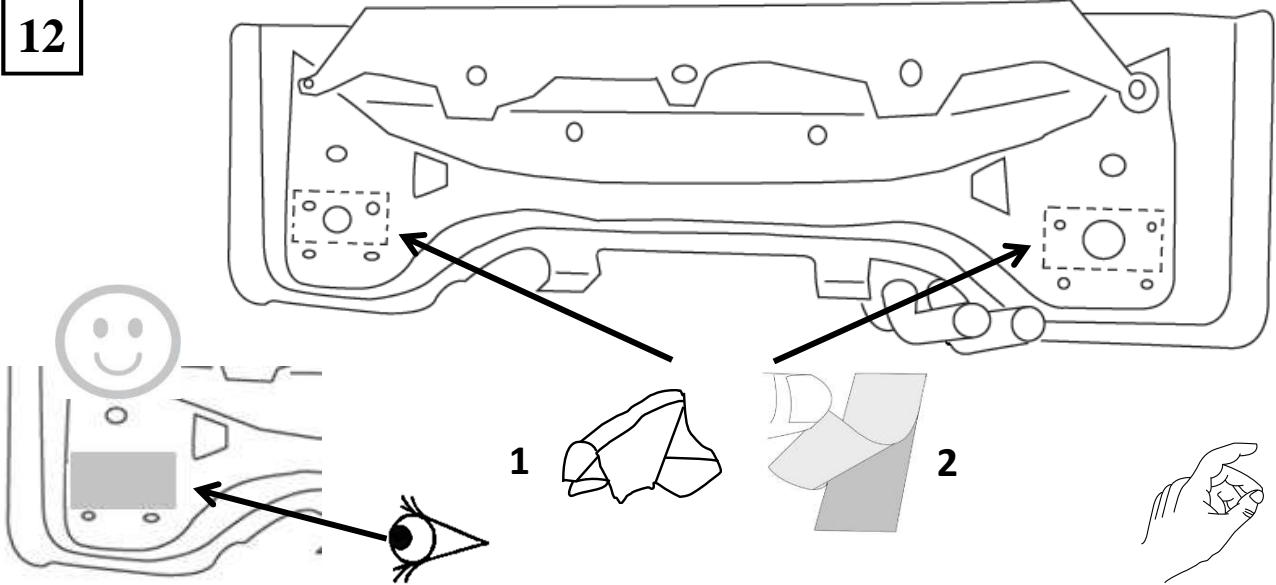



13

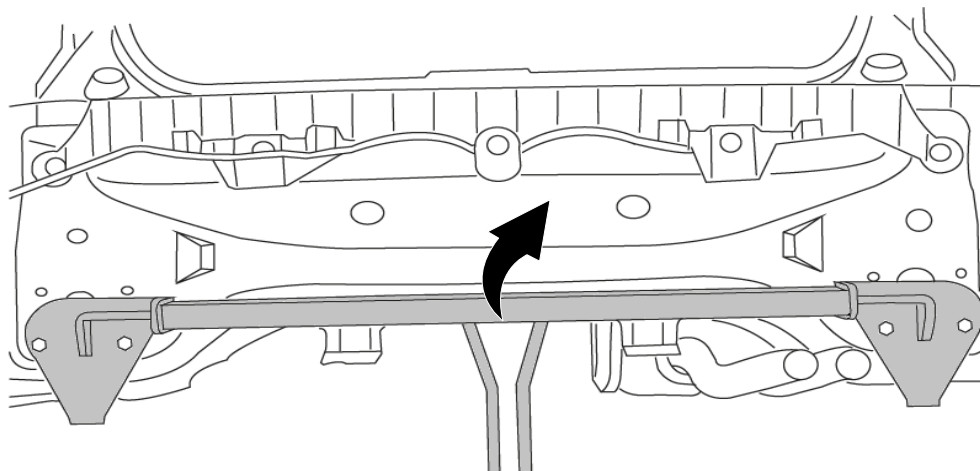
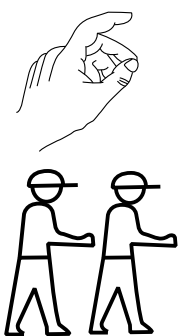

14

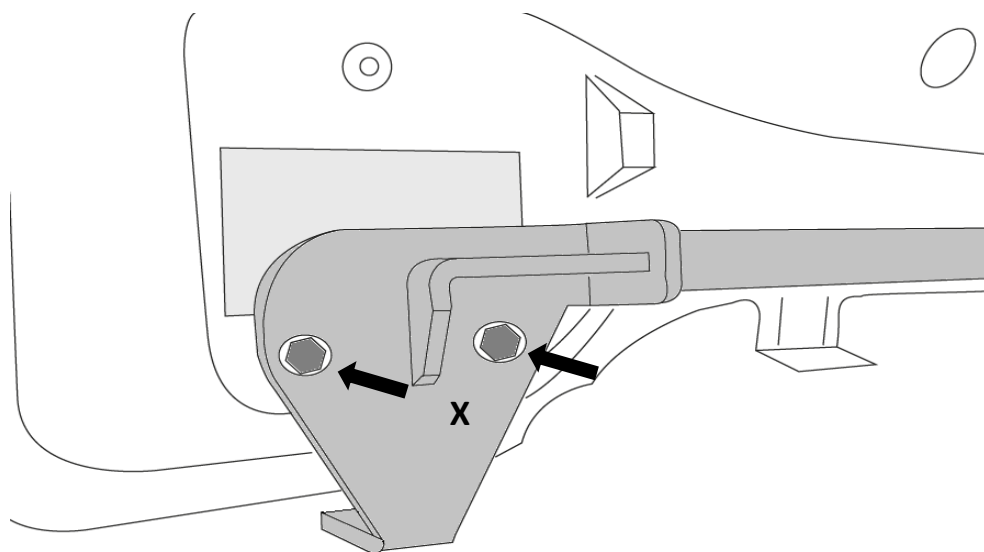
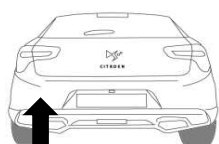

15

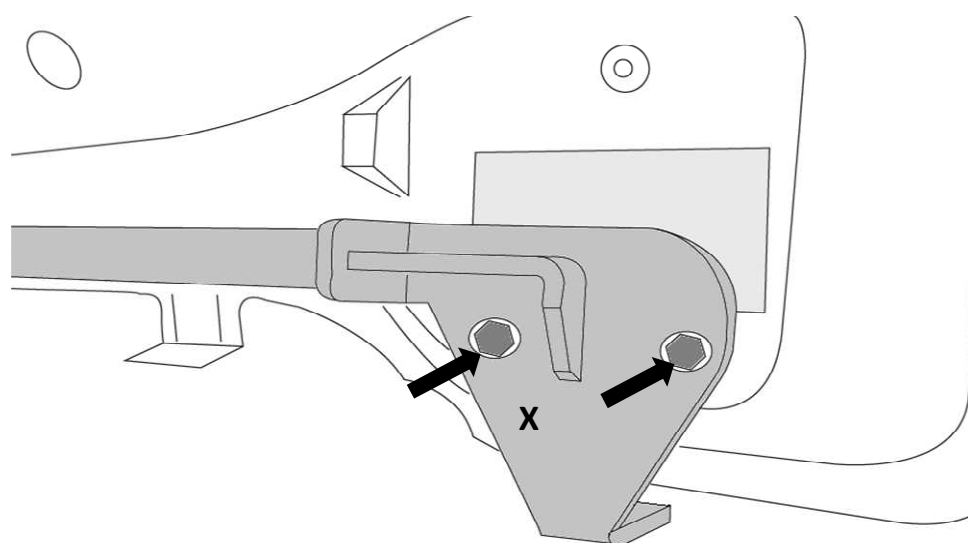
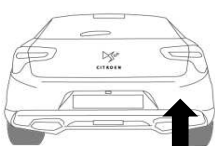

16

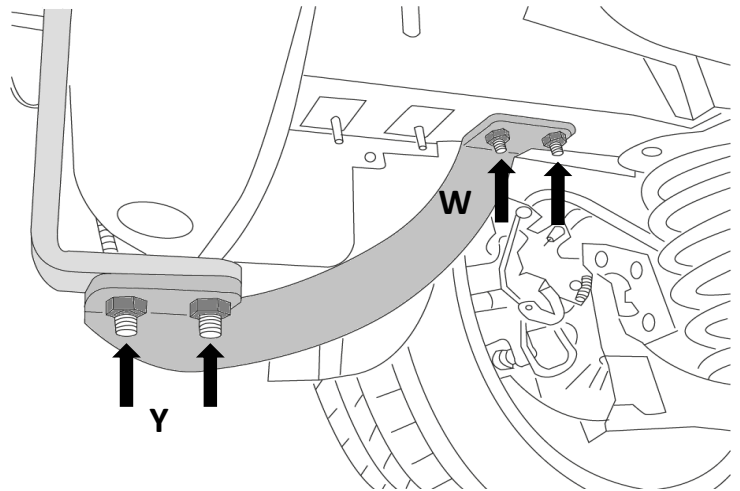
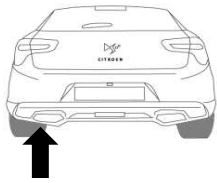

17

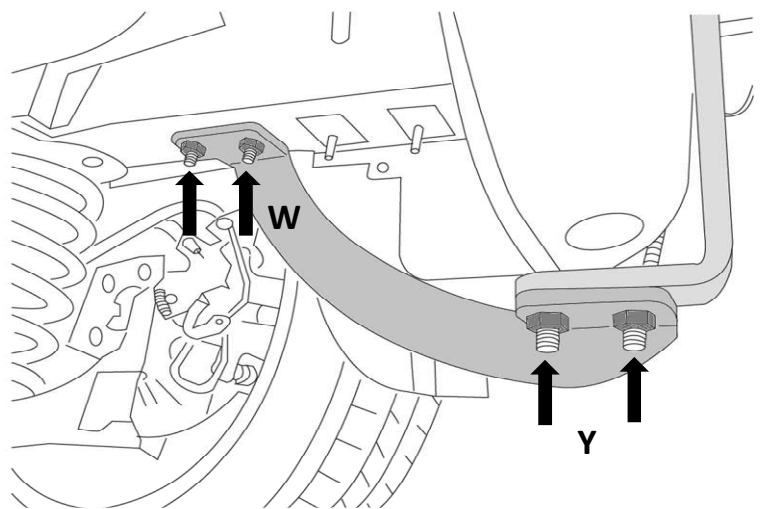
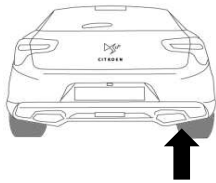

18

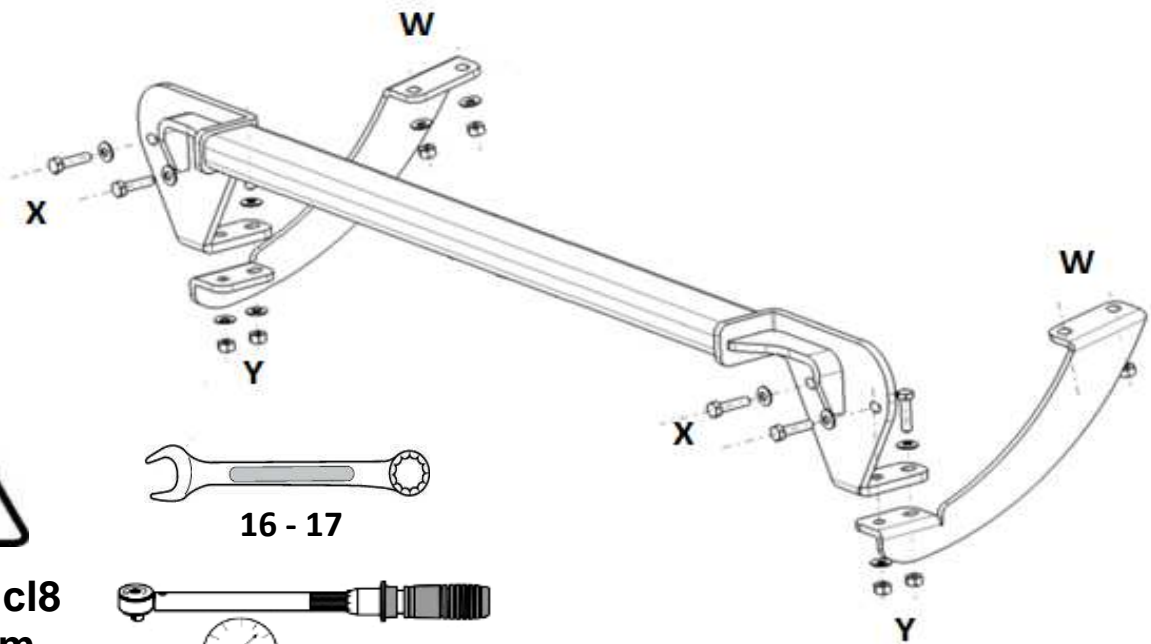

M10 - c18  
47 Nm



16 - 17



16 - 17

17

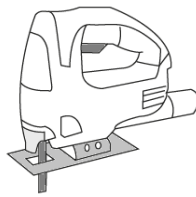
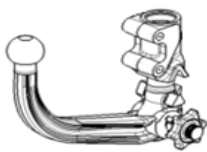
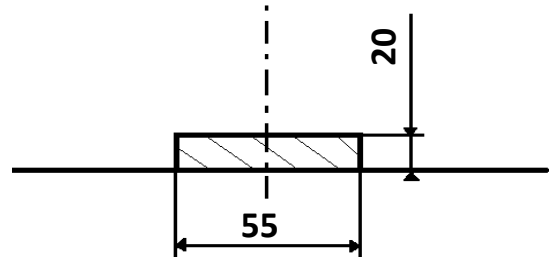
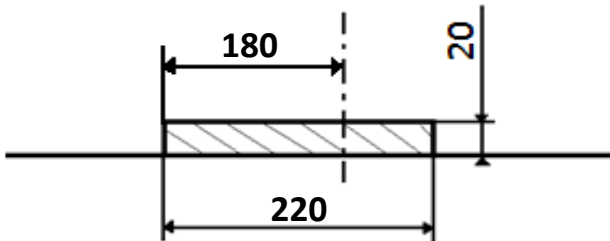
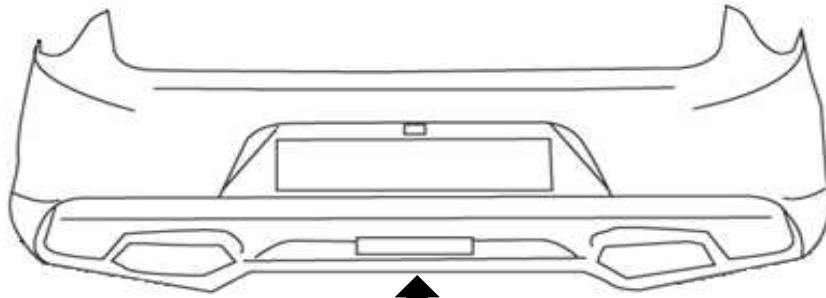

18

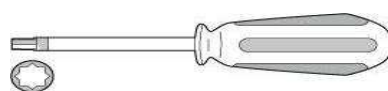
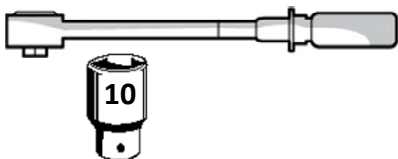
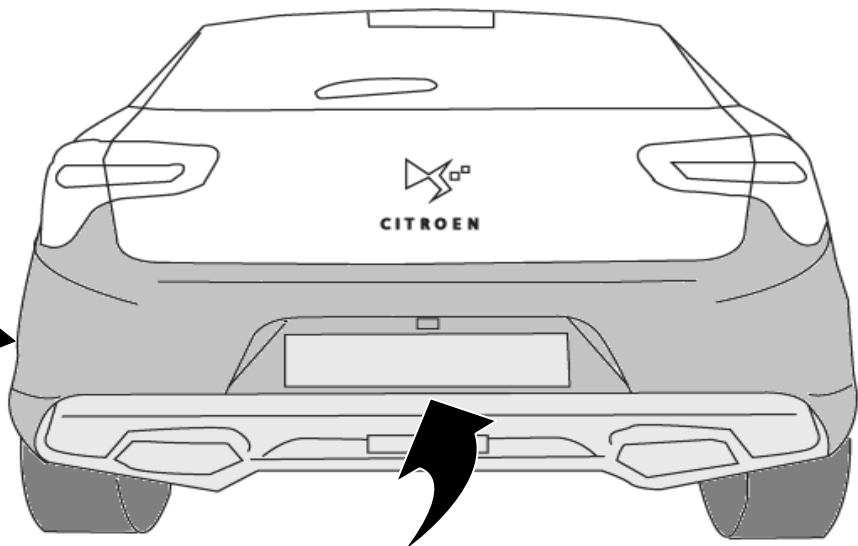
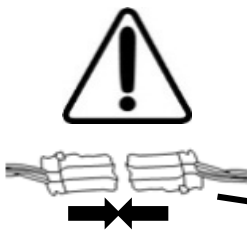

19



M12 - c110  
114 Nm

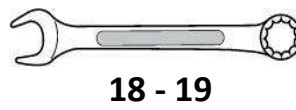
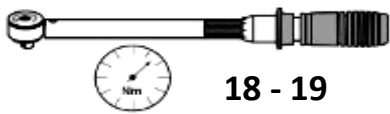
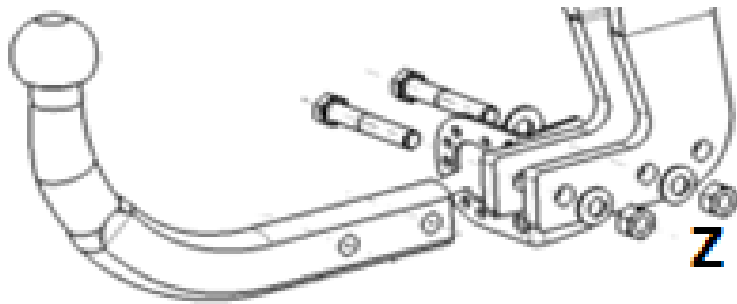

20



M12 - c110  
114 Nm

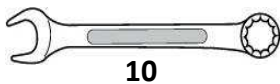
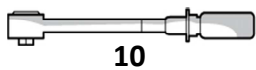
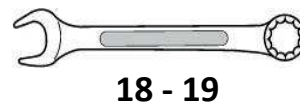
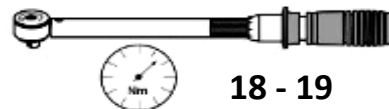
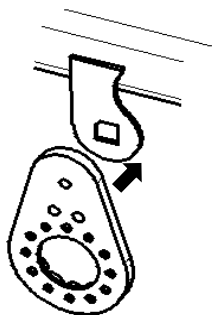
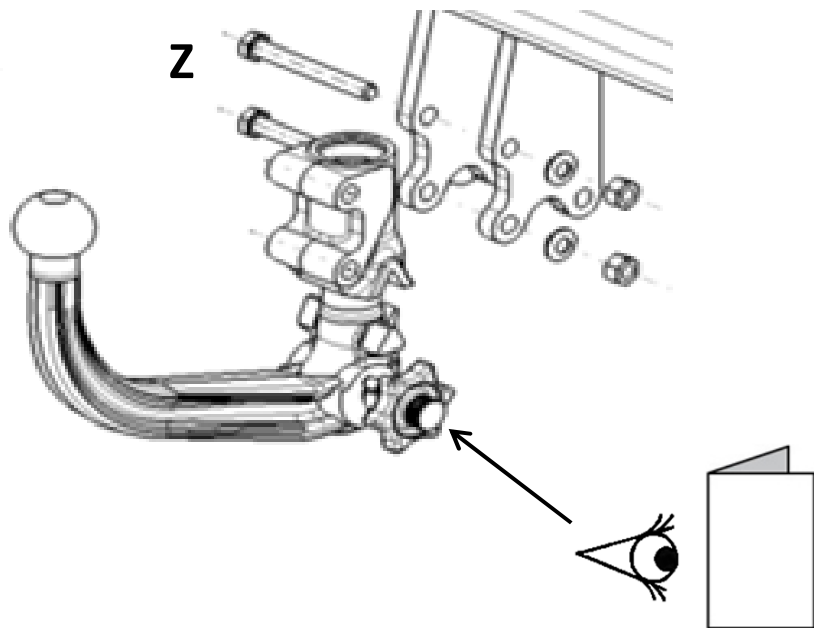

Dispositivo di traino tipo : **304149 - 304153**  
Per autoveicolo : **Citroen DS5**  
Tipo funzionale : **K\*\*\*\*\*/\***

**WESTFALIA**

*Monoflex*



Classe e tipo di attacco : **A50-X**  
Omologazione : **e24\*55R\*01 0323 (304 153) - e24\*55R\*01 0324 (304 149)**  
Valore D : **8,65 kN**  
Carico verticale max. S : **75 kg**  
Massa rimorchiabile : vedi carta di circolazione dell'autoveicolo

In base alla Direttiva europea R55, la massa massima rimorchiabile del dispositivo di traino è determinata dal valore di prova "D" così definito :

$$D = (T \times C) / (T + C) \times 0,00981 = 8,65 \text{ kN}$$

dove : T = Massa complessiva max. della motrice (in kg) e C = Massa rimorchiabile max. della motrice (in kg)

**DICHIARAZIONE DI CORRETTO MONTAGGIO :**

la sottoscritta Ditta dichiara che il dispositivo di traino tipo \_\_\_\_\_ è stato installato a regola d'arte, nel rispetto dei punti d'attacco e delle prescrizioni fornite dalla Casa costruttrice

sul veicolo Citroen DS5

targato \_\_\_\_\_

li \_\_\_\_\_

timbro et firma

Si dichiara inoltre di aver informato l'utente del veicolo sull'USO e MANUTENZIONE del dispositivo stesso.