



Instructions de montage du faisceau
électrique pour crochet d'attelage
conforme à la norme
DIN/ISO 1724 prise 12-N

Fitting instructions electric wiringkit
towbar with 12-N socket up to
DIN/ISO norm 1724

Montage-handleiding elektrokabelset voor
trekhaak met 12-N contactdoos
vlg. DIN/ISO norm 1724

Instrucciones de montaje de kit eléctrico para enganche de
remolque con caja de conexiones 12-N según norma
DIN/ISO 1724

Istruzioni di montaggio di set di cavi elettrici per gancio da
trains con zoccolo a 12 N conforme alla norma DIN/ISO
1724

Monteringsanvisningar elkabelsats för dragkrok med 12-N
kontaktdosa enligt DIN/ISO norm 1724

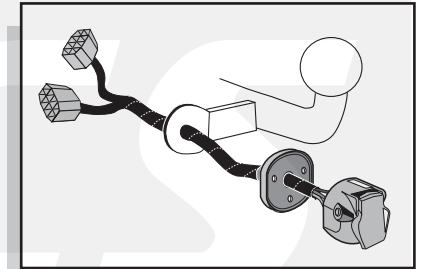

FIAT STILO WAGON 2003-

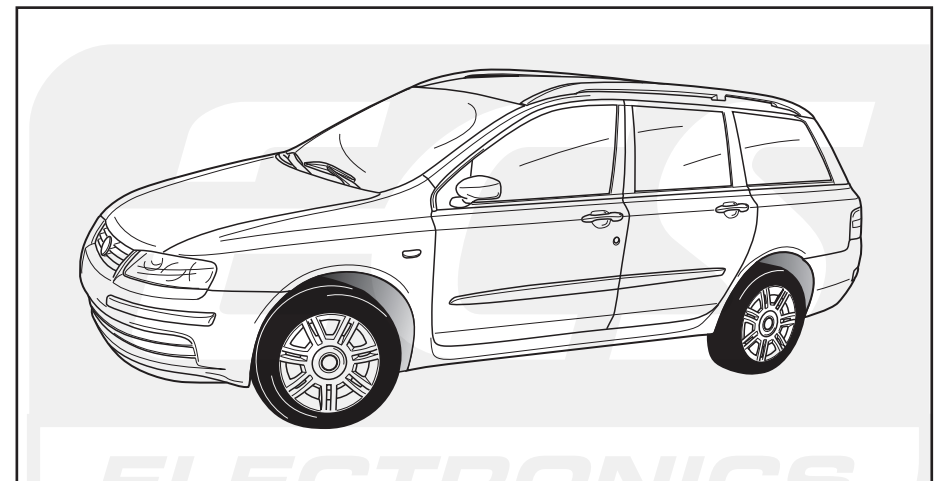

Bestel Nr.: FI-012-BB

*Einzelteilliste *Liste de pieces *Part list *Onderdelenlijst
*Lista de componentes *Elenco componenti *Dellista

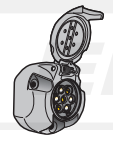
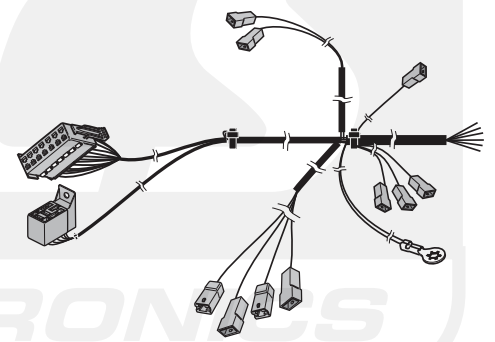
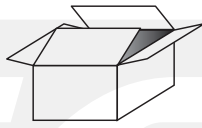

Orange
Orange
Orange
Naranja
Arancione
Orange

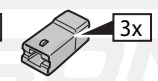
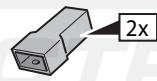
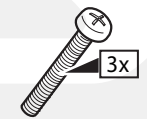
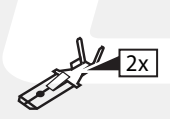
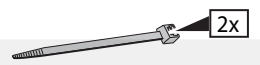
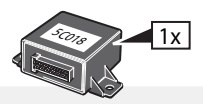
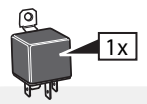



INFO

DE

- Wir weisen ausdrücklich darauf hin, dass eine unsachgemäße und nicht in einer Fachwerkstatt durchgeführte Montage einen Verzicht auf Entschädigung jeglicher Art insbesondere bezüglich des Produkthaftpflichtrechts zur Folge hat.
- Technische Änderungen vorbehalten.
- Widerstand nur gemäß der Tabelle auf dem Anhänger verwenden, siehe Seite 3.

FR

- Il est expressément prévu qu' on ne saurait se prévaloir d'un quelconque préjudice contractuel ou réhibitoire si le montage avait été fait en dépit des dites instructions ou dans un garage ne disposant pas des équipements adéquats.
- Sous réserve de modifications techniques.
- Ne excédez pas la charge maximale, indiquée dans le tableau sur page 3.

GB

- We would expressly point out that any improper assembly which is not carried out in a specialist workshop will result in the renunciation of the enforcement of compensation claims of any kind, in particular those arising by virtue of the product liability law.
- Subject to alteration without notice.
- Only use maximum charge according to connection table on towed vehicle, see page 3.

NL

- Wij wijzen er met nadruk op, dat ondeskundige en niet door een vakkundige werkplaats uitgevoerde montage tot gevolg heeft dat daardoor ieder recht op schadevergoeding, ook op wettelijke aansprakelijkheid inzake producten, vervalst.
- Technische wijzigingen voorbehouden.
- Gebruik alleen belasting volgens aansluittabel op het getrokken voertuig, zie pagina 3.

ES

- El montaje inapropiado y efectuado por personal no cualificado originará la pérdida de todo derecho a indemnización o la expiración de toda responsabilidad civil con respecto al producto.
- Nos reservamos el derecho a efectuar modificaciones técnicas.
- Utilice sólo cargas de acuerdo a la tabla de conexión del vehículo remolcado (ver página 3).

IT

- Sottolineiamo espressamente che un montaggio inadeguato ed eseguito da un'officina non specializzata ha come conseguenza il decadere di qualsiasi diritto al risarcimento danni, nonché alla responsabilità legale relativa ai prodotti.
- Ci si riserva il diritto di apportare modifiche tecniche.
- Utilizzare esclusivamente un carico conforme alla tabella degli allacci relativa al veicolo in questione, cfr. pagina 3.

SE

- Vi påpekar med eftertryck att all rätt till skadeersättning och all laglig ansvarighet förfaller om monteringen inte har utförts på rätt sätt och av en professionell verkstad.
- Tekniska ändringar förbehålles.
- Använd endast belastning enligt anslutningstabellen på det dragna fordonet, se sid. 3.

1

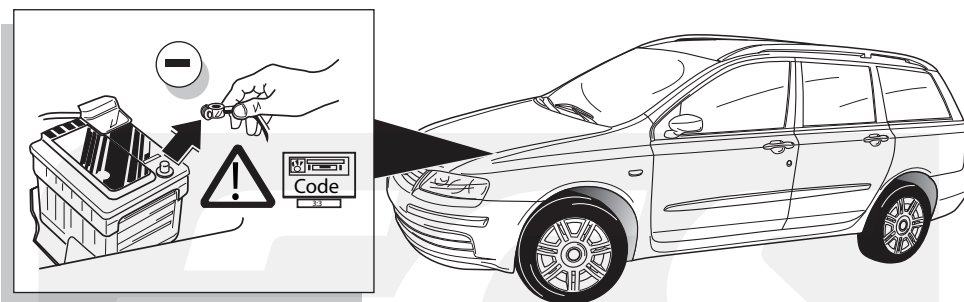

2

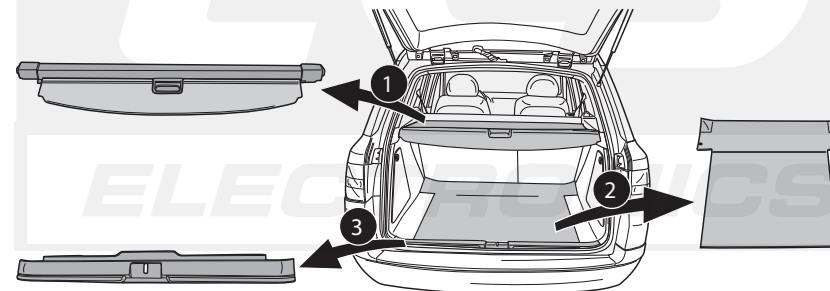

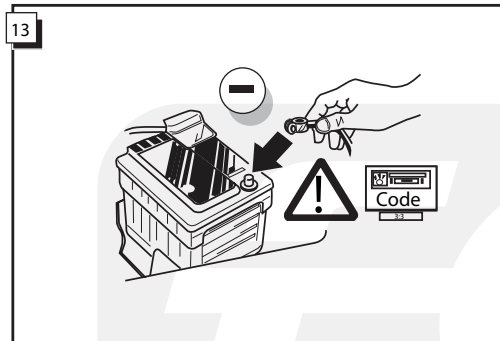
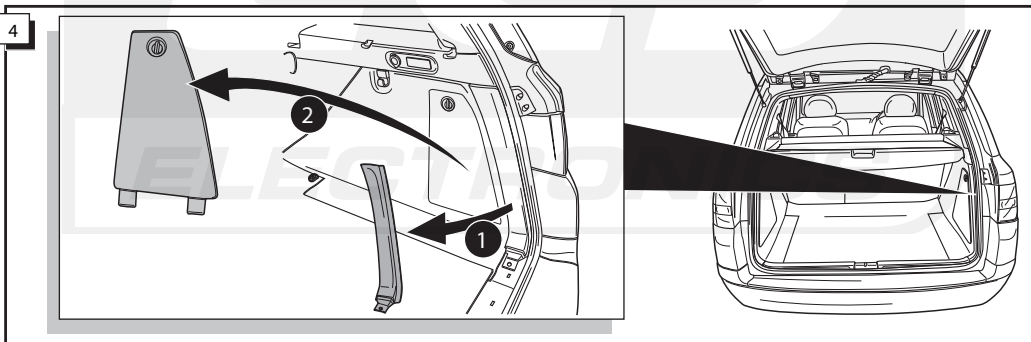
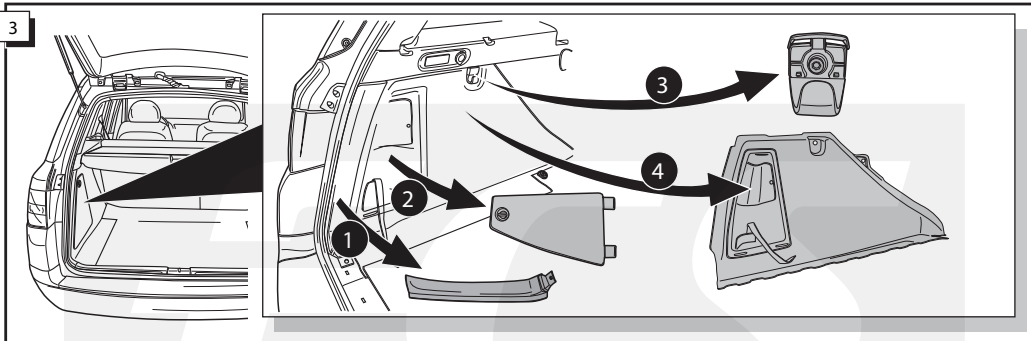

- 14
- (DE) FUNKTIONEN KONTROLLIEREN !
 - (FR) CONTRÔLER LES FONCTIONS !
 - (GB) CHECK FUNCTIONS !
 - (NL) CONTROLEER FUNCTIES !
 - (ES) ¡ CONTROLAR FUNCIONES !
 - (IT) CONTROLLA FUNZIONI !
 - (SE) KONTROLLERA FUNKTIONERNA !

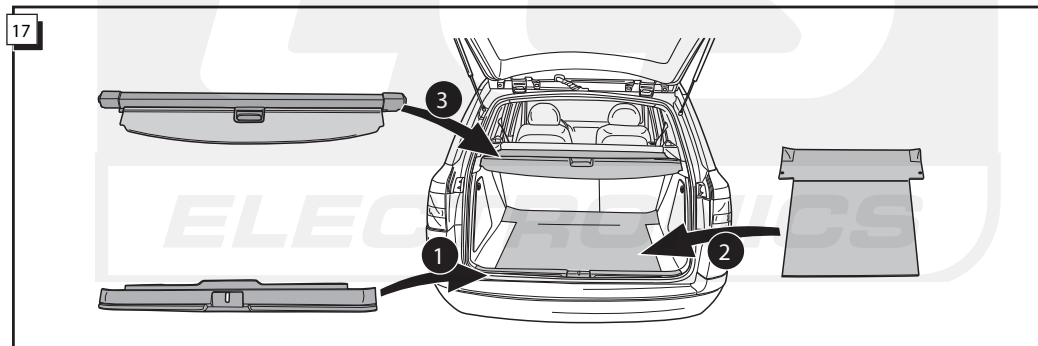
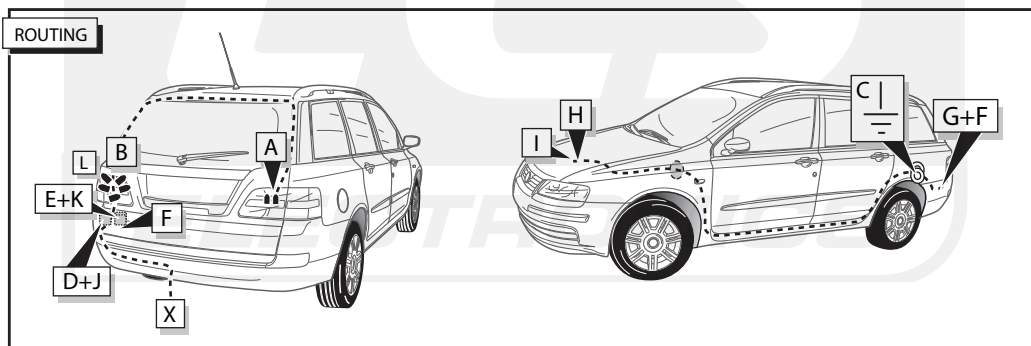
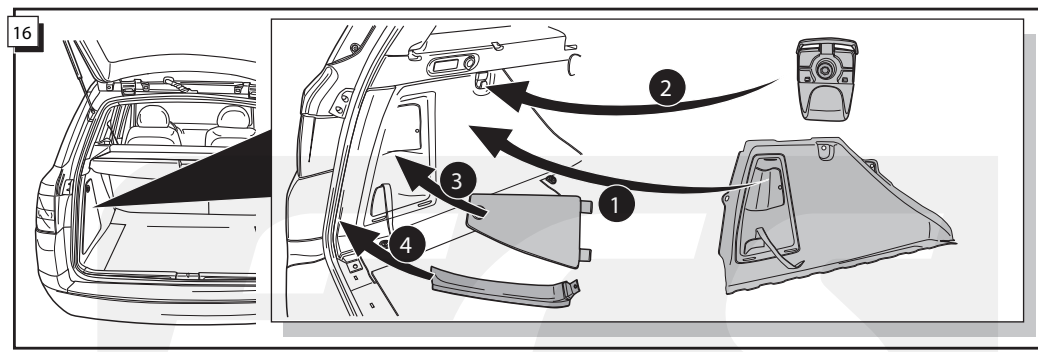
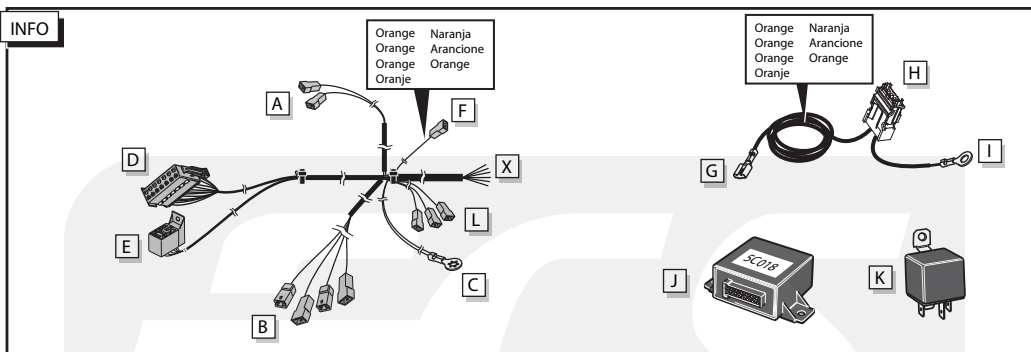
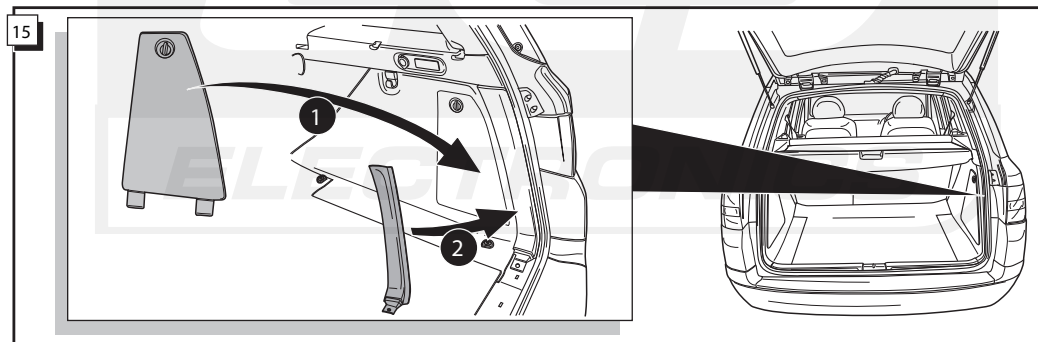

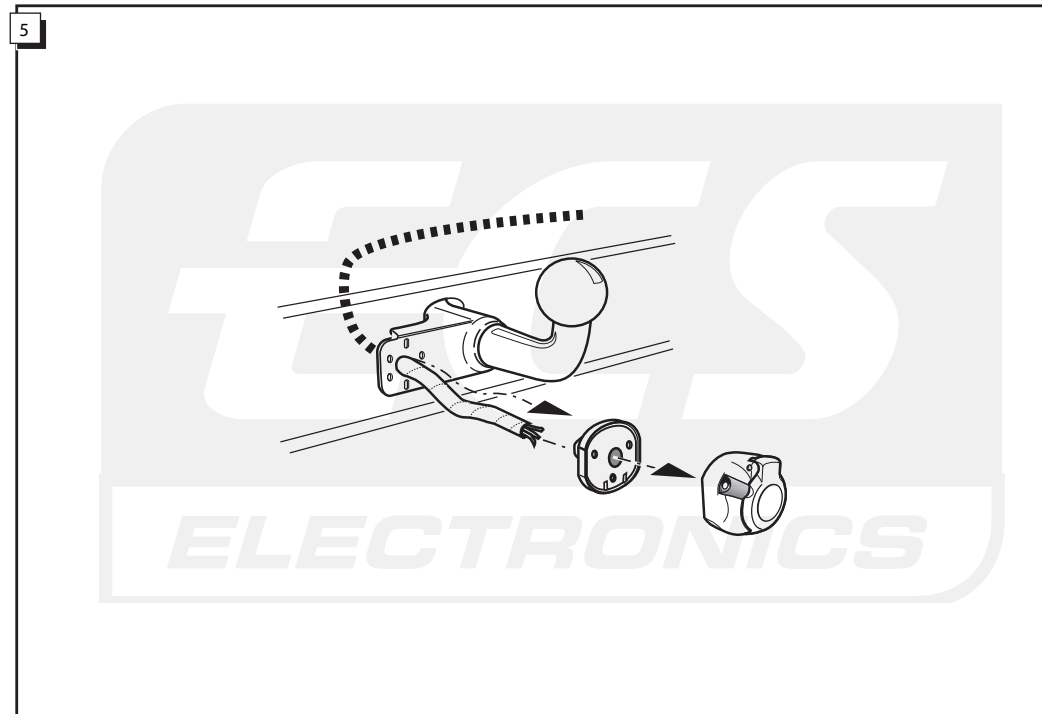
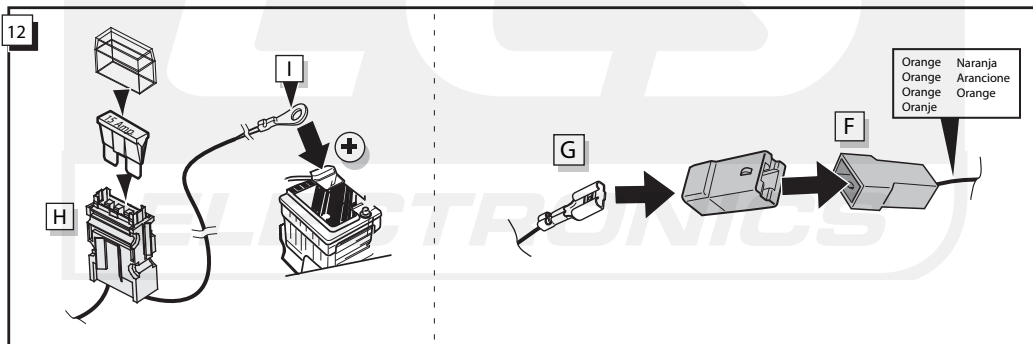
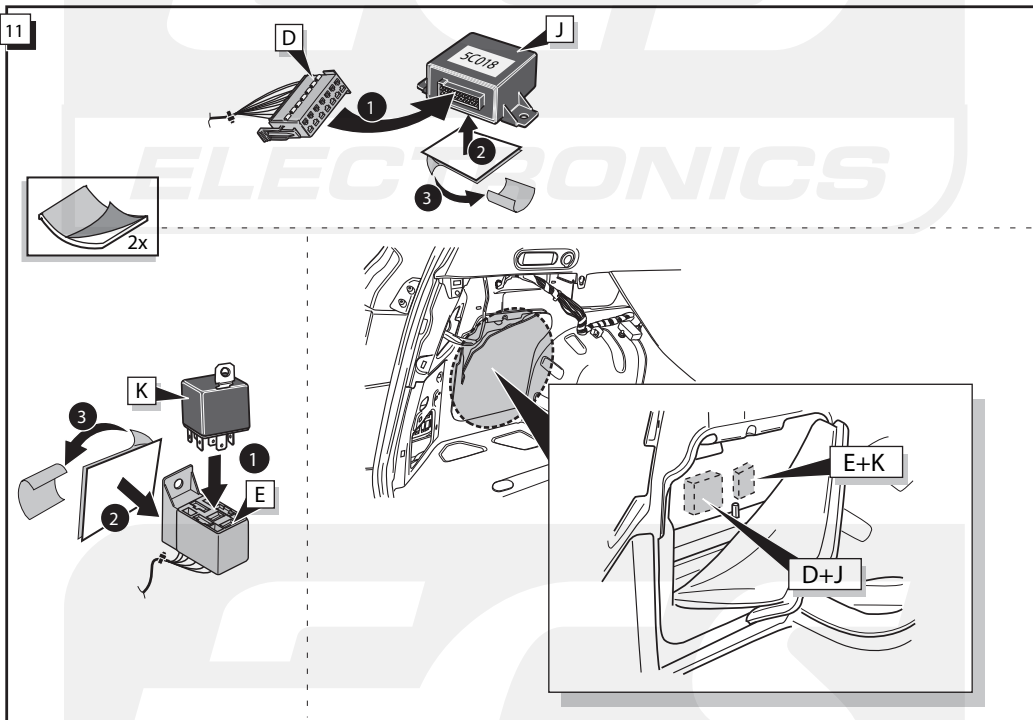
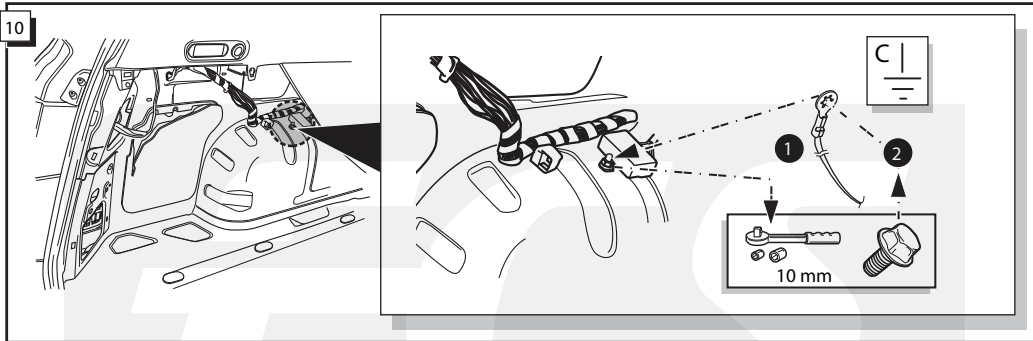

6

Anschluss Steckdose / Connection de la prise / Socket connection / Contactdoos aansluiting
Conexión de la caja de enchufe / Allaccio zoccolo / Anslutning kontaktdosa

INFO									
DIN/ISO 1724		DE	FR	GB	NL	ES	IT	SE	Pmax
↶	1/L	gelb	jaune	yellow	geel	amarillo	giallo	gul	21W
↷	2	blau	bleu	blue	blauw	azul	blu	blå	2x21W
⊖	1-8	weiß	blanc	white	wit	blanco	bianco	vit	
↶	4/R	grün	vert	green	groen	verde	verde	grön	21W
☀	5/58-R	braun	marron	brown	bruin	marrón	marrone	brun	52W
STOP	6/54	rot	rouge	red	rood	rojo	rosso	röd	3x21W
☀	7/58-L	schwarz	noir	black	zwart	negro	nero	svart	52W

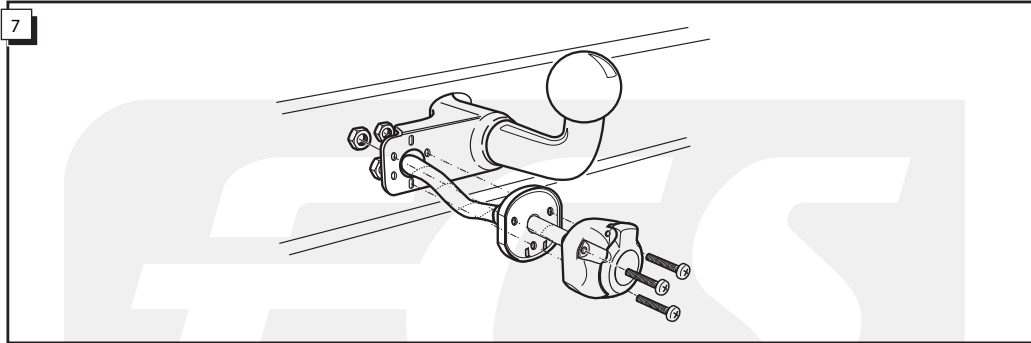

8

1 2 3 4

Kabel Kabelsatz Fil faisceau Wire harness Draad kabelboom Cable, haz de cables Cavi cablaggio Ledare kabelbunt		Lokalisieren und überprüfen Sie die Funktionen. Localisez et vérifiez les fonctions. Locate and check functions. Lokaliseer en meet de functies door. Localizar y probar funciones. Individui e controllli le funzioni. Mätning funktioner.	
A	Schwarz/Braun Noir/Marron Black/Brown Zwart/Bruin Negro/Marrón Nero/Marrone Svart/Brun	 58 R	
A	Schwarz/Grün Noir/Vert Black/Green Zwart/Groen Negro/Verde Nero/Verde Svart/Grön	 R	
L	Blau/Rot Bleu/Rouge Blue/Red Blauw/Rood Azul/Rojo Blu/Rosso Blå/Röd	 54	
L	Violett/Schwarz Violet/Noir Purple/Black Paars/Zwart Morado/Negro Viola/Nero Lila/Svart	 58 L	
L	Schwarz/Gelb Noir/Jaune Black/Yellow Zwart/Geel Negro/Amarillo Nero/Giallo Svart/Gul	 L	

9

Lokalisieren und überprüfen Sie die Funktionen.
 Localisez et vérifiez les fonctions.
 Locate and check functions.
 Lokaliseer en meet de functies door.
 Localizar y probar funciones.
 Individui e controllli le funzioni.
 Mätning funktioner.

Grau
 Gris
 Grey
 Grijs
 Gris
 Grigio
 Grå

54G

1 2

Kabel Kabelsatz
 Fil faisceau
 Wire harness
 Draad kabelboom

Cable, haz de cables
 Cavi cablaggio
 Ledare kabelbunt

Rot/Weiß
 Rouge/Blanc
 Red/White
 Rood/Wit
 Rojo/Blanco
 Rosso/Bianco
 Röd/Vit

Grau
 Gris
 Grey
 Grijs
 Gris
 Grigio
 Grå

54G

Grau
 Gris
 Grey
 Grijs
 Gris
 Grigio
 Grå

54G

Lokalisieren und überprüfen Sie die Funktionen.
 Localisez et vérifiez les fonctions.
 Locate and check functions.
 Lokaliseer en meet de functies door.
 Localizar y probar funciones.
 Individui e controllli le funzioni.
 Mätning funktioner.

Rosa
 Rose
 Pink
 Roze
 Rosa
 Rosa

54G

Kabel Kabelsatz
 Fil faisceau
 Wire harness
 Draad kabelboom

Cable, haz de cables
 Cavi cablaggio
 Ledare kabelbunt

Rot/Gelb
 Rouge/Jaune
 Red/Yellow
 Rood/Geel
 Rosso/Giallo

Rosa
 Rose
 Pink
 Roze
 Rosa
 Rosa

54G

Rosa
 Rose
 Pink
 Roze
 Rosa
 Rosa

54G

4