

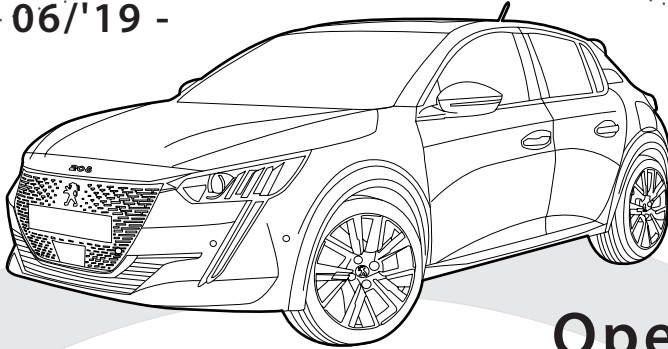

TREKHAKEN • ATTELAGES • ANHÄNGERVORRICHTUNGEN • TOWBARS • ENHANCES • ANHÆNGERTRÆK
Montagehandleiding | instructions de montage | Einbauanleitung | Mounting instruction
Instrucciones de montaje | monteringsvejledning

Peugeot e208 II (UB, UP, UW) 06/'19 -



Opel Corsa-e F 07/'19 -

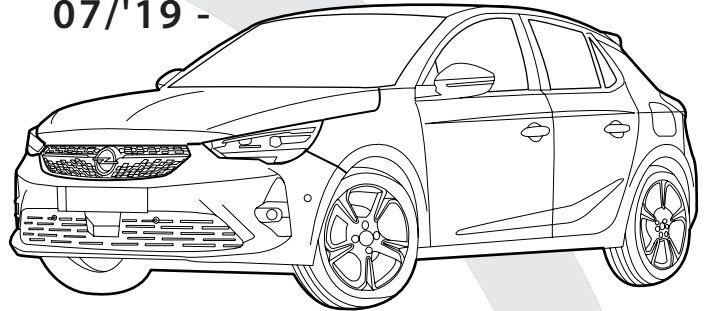

Opel Mokka-e 06/'20 -

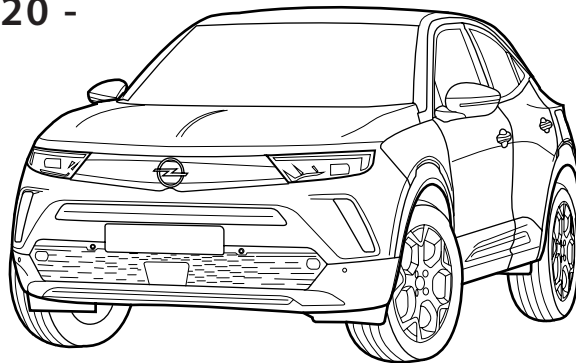

DS3 Crossback E-Tense (UR, UC, UJ) 05/'19-

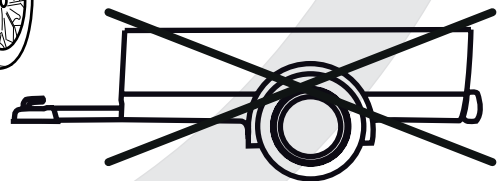
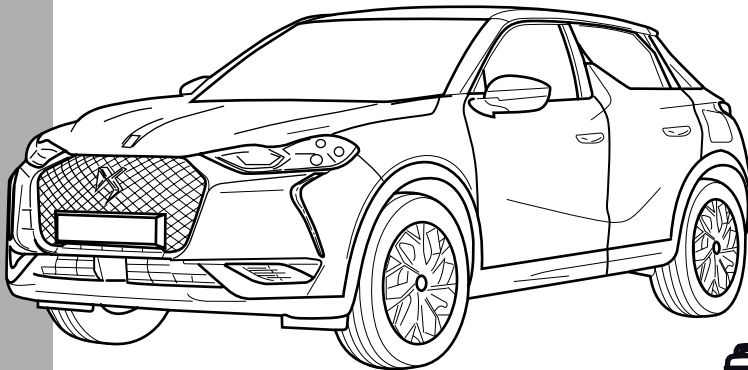

NO TOWING

NL Belangrijke raadgevingen

Montage

- Voor de montage moet de fietsdragerconstructie eerst op het voertuig gepresenteerd worden.

De belasting van een accessoire dat op de koppelingskogel wordt voorzien is anders van aard.

Voor deze accessoires kunnen verschillende limieten van toepassing zijn. Hiervoor verwijzen we naar het instructieboekje van de wagen of naar uw concessiehouder.

FR Recommandations importantes

Montage

- Présenter la construction porte-vélos sous le véhicule avant d'effectuer le montage.

La charge d'une accessoire prévue sur la boule d'attelage, est de nature diverse.

Pour les accessoires, il peut y avoir des limites d'utilisation différentes. Nous vous recommandons de vous référer à votre livret d'instructions ou de vous renseigner chez votre concessionnaire.

EN General instructions

Fitting

- Present the bike carrier construction under the car first to check if all points are right.

The load of an accessory fitted on the towing ball is of a different nature. Different limits may apply.

For this matter, we refer to the instruction manual of the vehicle or we advise you to contact your concessionaire.

DE Wichtige ratschläge

Montage

- Erst die Konstruktion für Fahrradträger und das Fahrzeug kontrollieren, danach montieren.

Die Belastung eines Zubehörs, die man auf einer Kupplungskugel voraussieht, ist wesentlich anders. Für die Zubehöre geldet, dass diese unterschiedlich begrenzt sein können. Deswegen möchten wir verweisen auf die Bedienungsanleitung des Fahrzeugs oder auf Ihren Vertragshändler.

ES Instrucciones generales

Montaje

- Presentar la construcción para portabicicletas debajo del vehículo antes de realizar el montaje.

La carga de un accesorio montado en una bola de remolque son de una naturaleza diferente. Se pueden aplicar diferentes límites a ambos. Para este asunto, nos referimos al manual de instrucciones del vehículo o le recomendamos que contacte a su distribuidor.

DK Generelle instruktioner

Montering

- Præsenter konstruktionen til cykelholdere under bilen først for at kontrollere, om alle punkter er rigtige.

Belastningen af tilbehør tilkoblet anhængertrækket er forskellige. Der kan være forskellige begrænsninger på begge. I disse tilfælde henviser vi til bilens manual, eller anbefaler dig at kontakte bilforhandleren

IT Consigli importanti

Montaggio

- In primo luogo, presentare la struttura sotto l'automobile per verificare che tutti i punti di attacco coincidano.

La massa rimorchiabile del veicolo potrebbe essere diversa dal valore riportato sul documento del gancio di traino.

Per questo motivo, vi invitiamo a consultare sempre la carta di circolazione del veicolo (Pos. O.1) o a rivolgervi alla vostro concessionario di fiducia

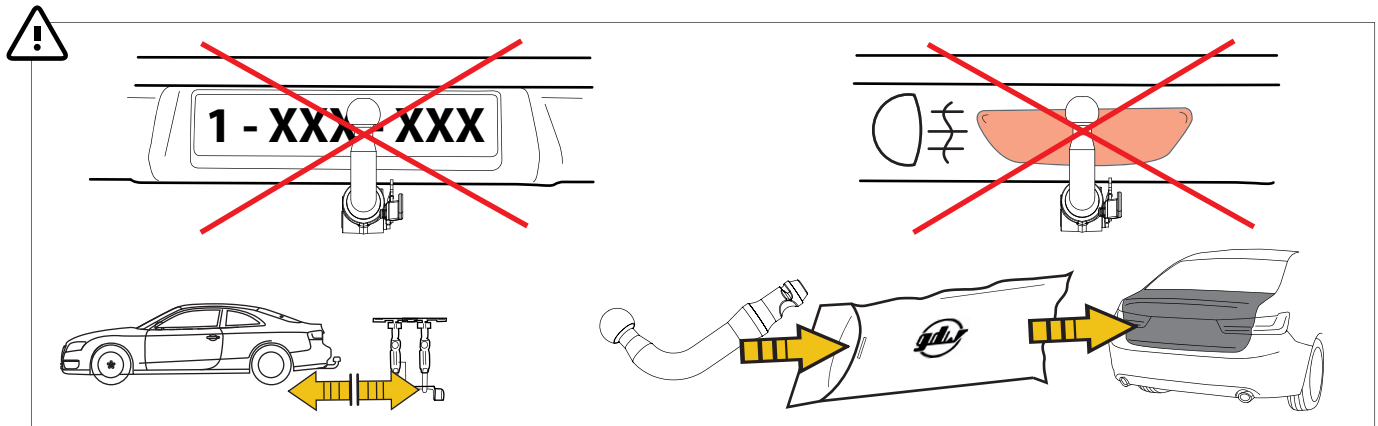
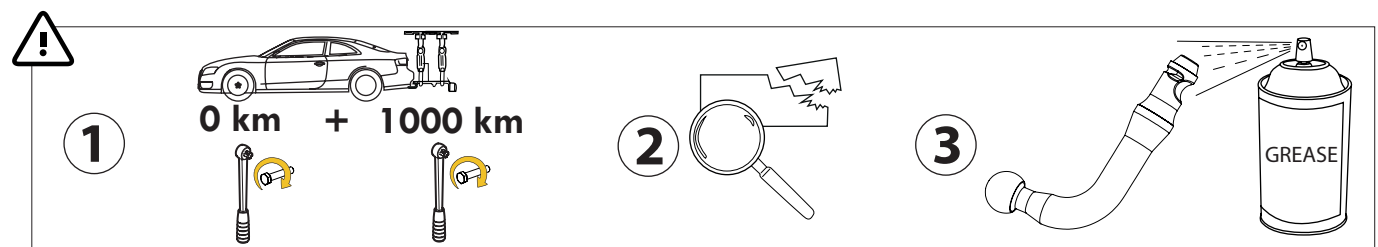
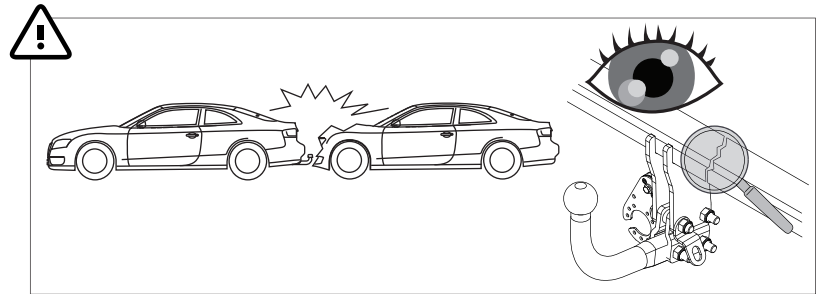
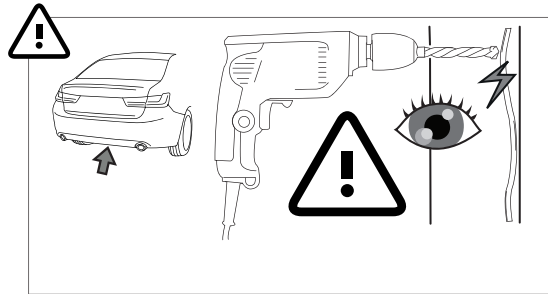
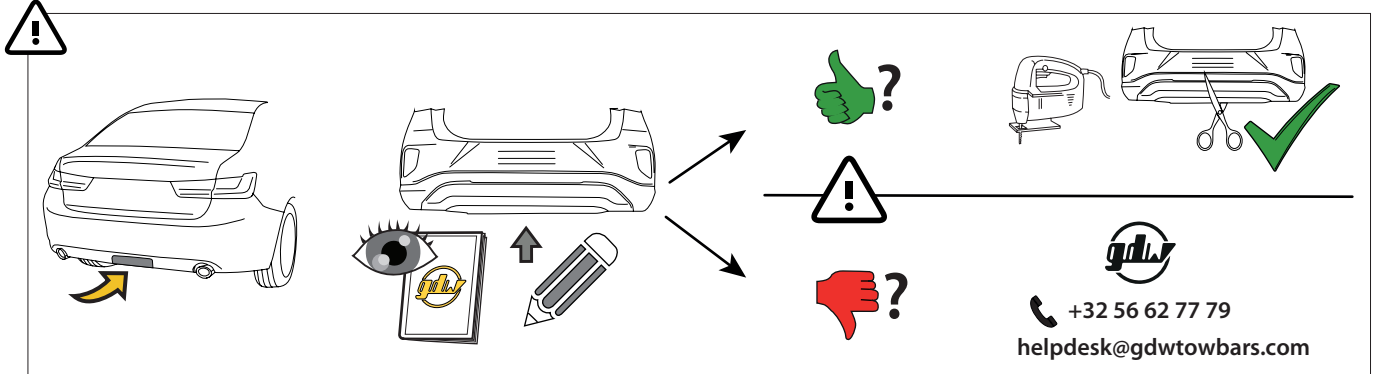
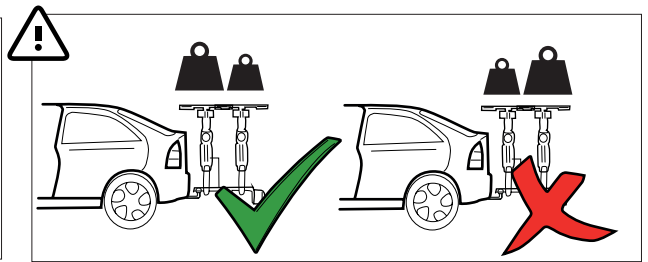
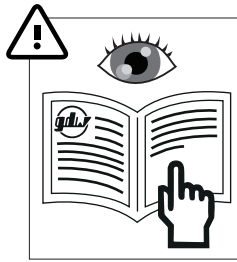
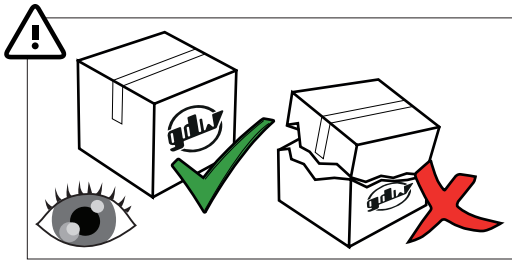

MADE BY



BELGIUM

NO TOWING

REF N°

2567T60

SERIAL N°

xxx

D 0,00

DISCRIPTION

Peugeot e-208 & Opel Corsa-e & Opel Mokka-e & DS3 Crossback E-Tense

NO TOWING

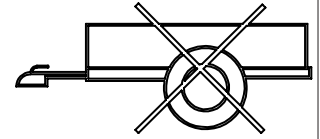
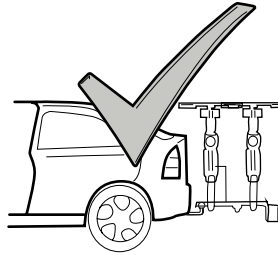

S =

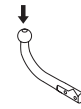

= 75 kg

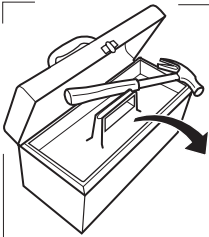

10



13



17



19

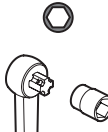

TX20

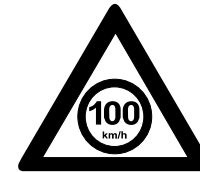
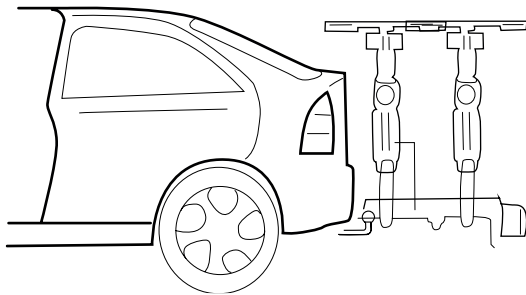
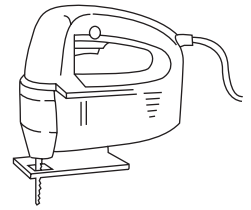
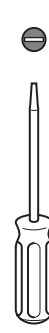

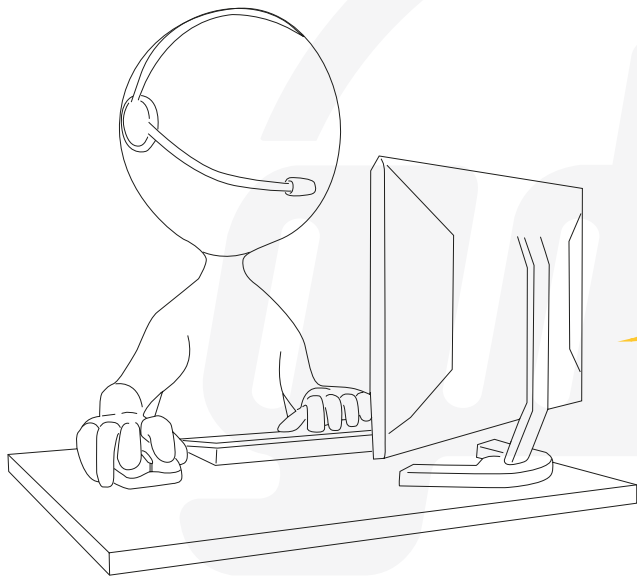

helpdesk@gdwtowbars.com
+32 56 62 77 79

Monday	08:00 - 12:00	12:30 - 16:30
Tuesday	08:00 - 12:00	12:30 - 16:30
Wednesday	08:00 - 12:00	12:30 - 16:30
Thursday	08:00 - 12:00	12:30 - 16:30
Friday	08:00 - 12:00	12:30 - 15:30

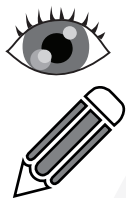

KEY NUMBER
[Empty box for key number]

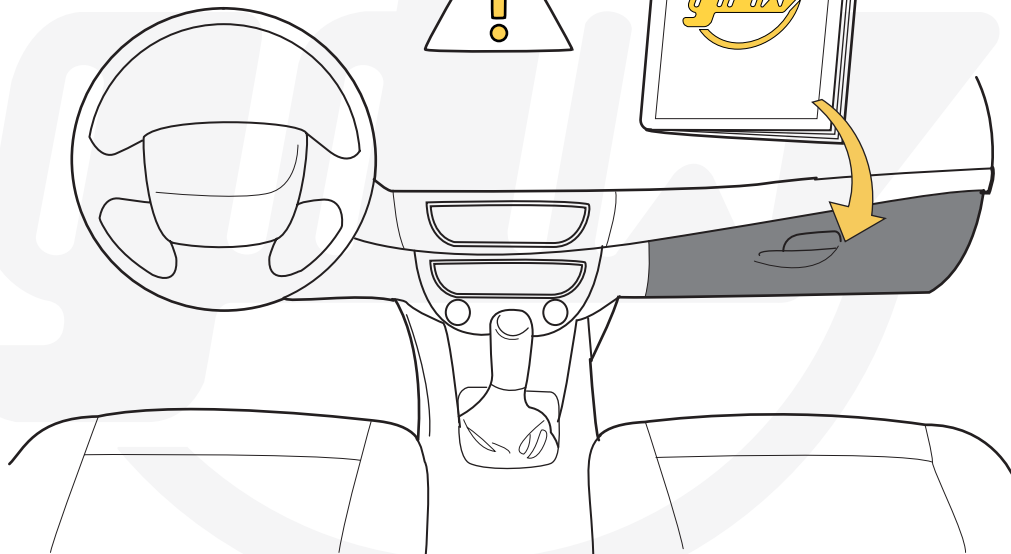

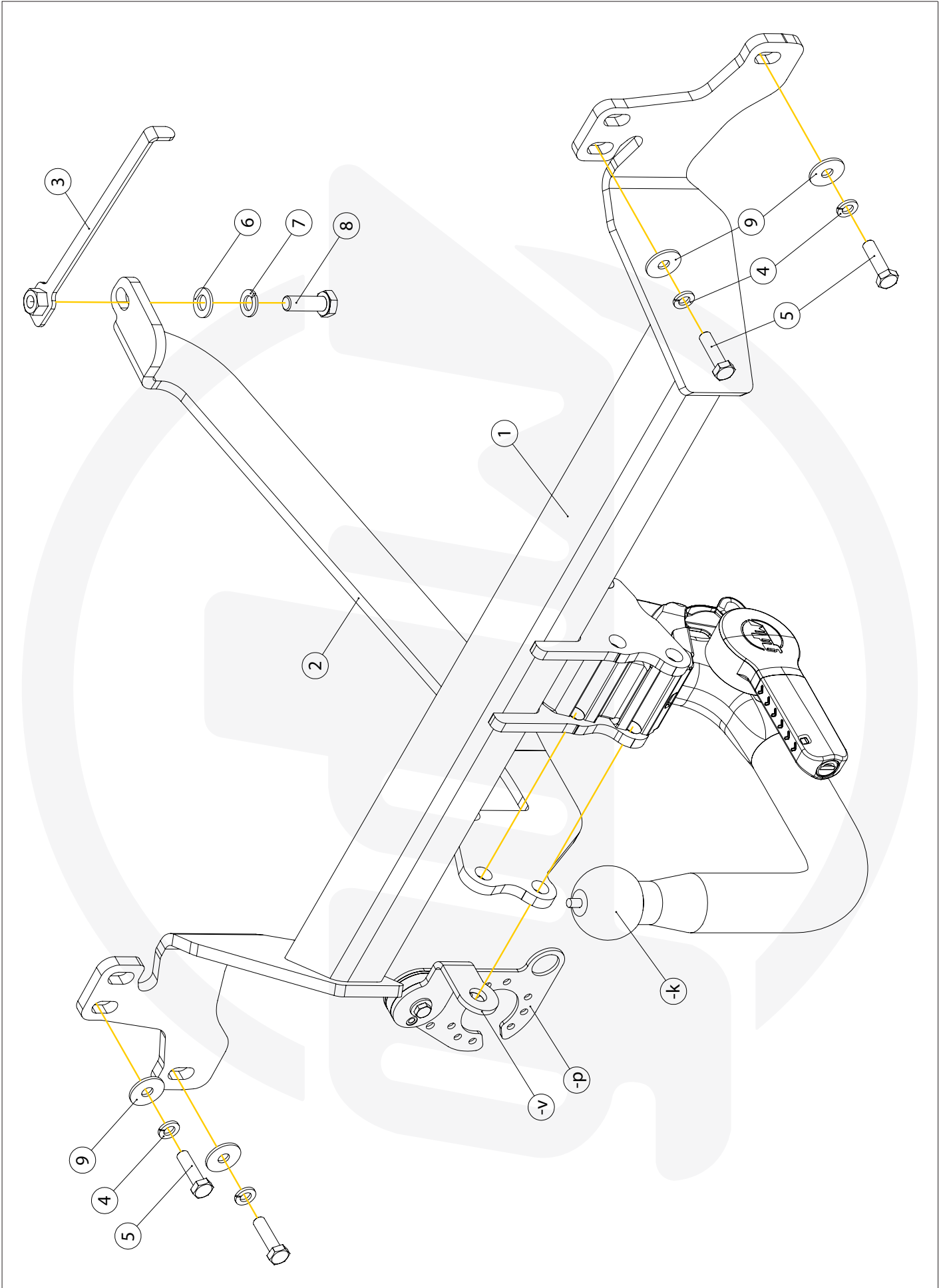

1

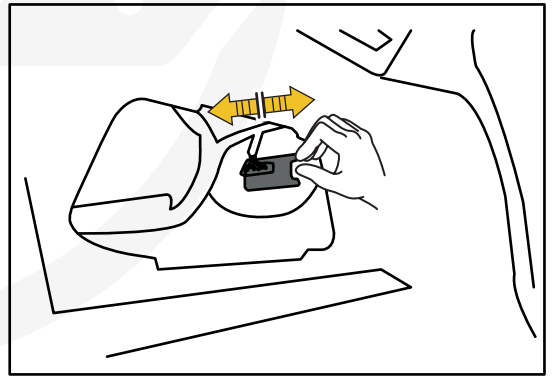
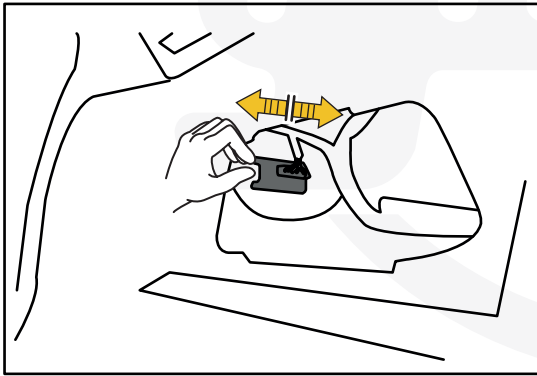
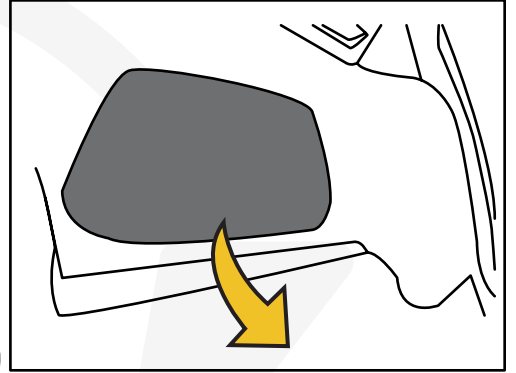
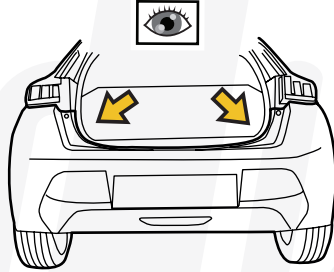
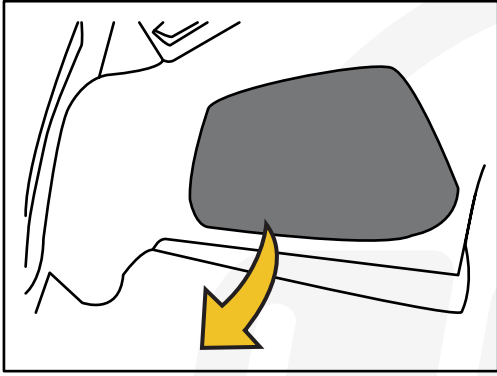

2

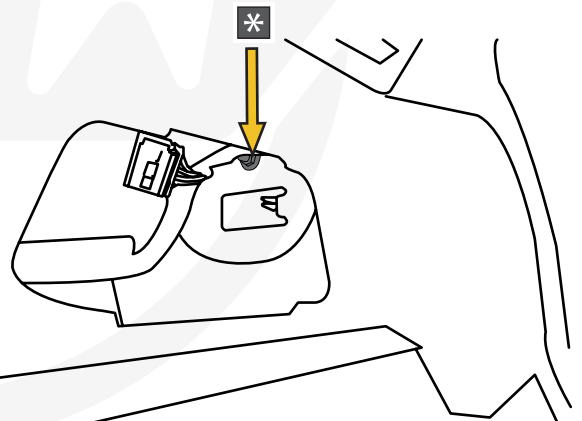
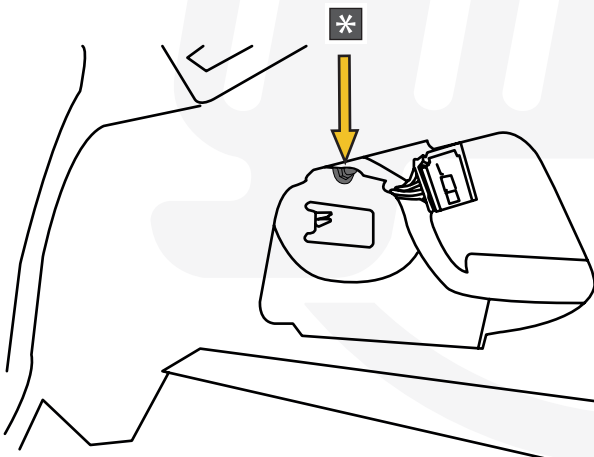
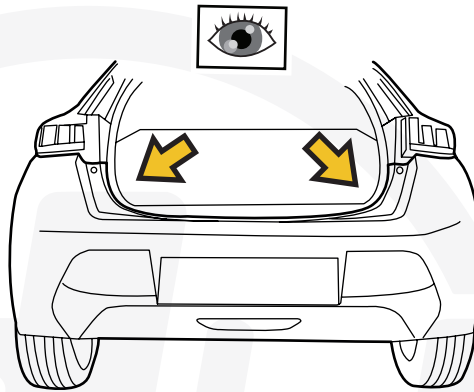
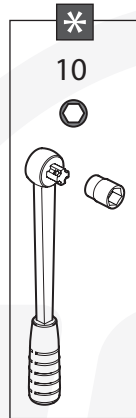

3

* PEUGEOT e-208

● DS3 Crossback E-tense

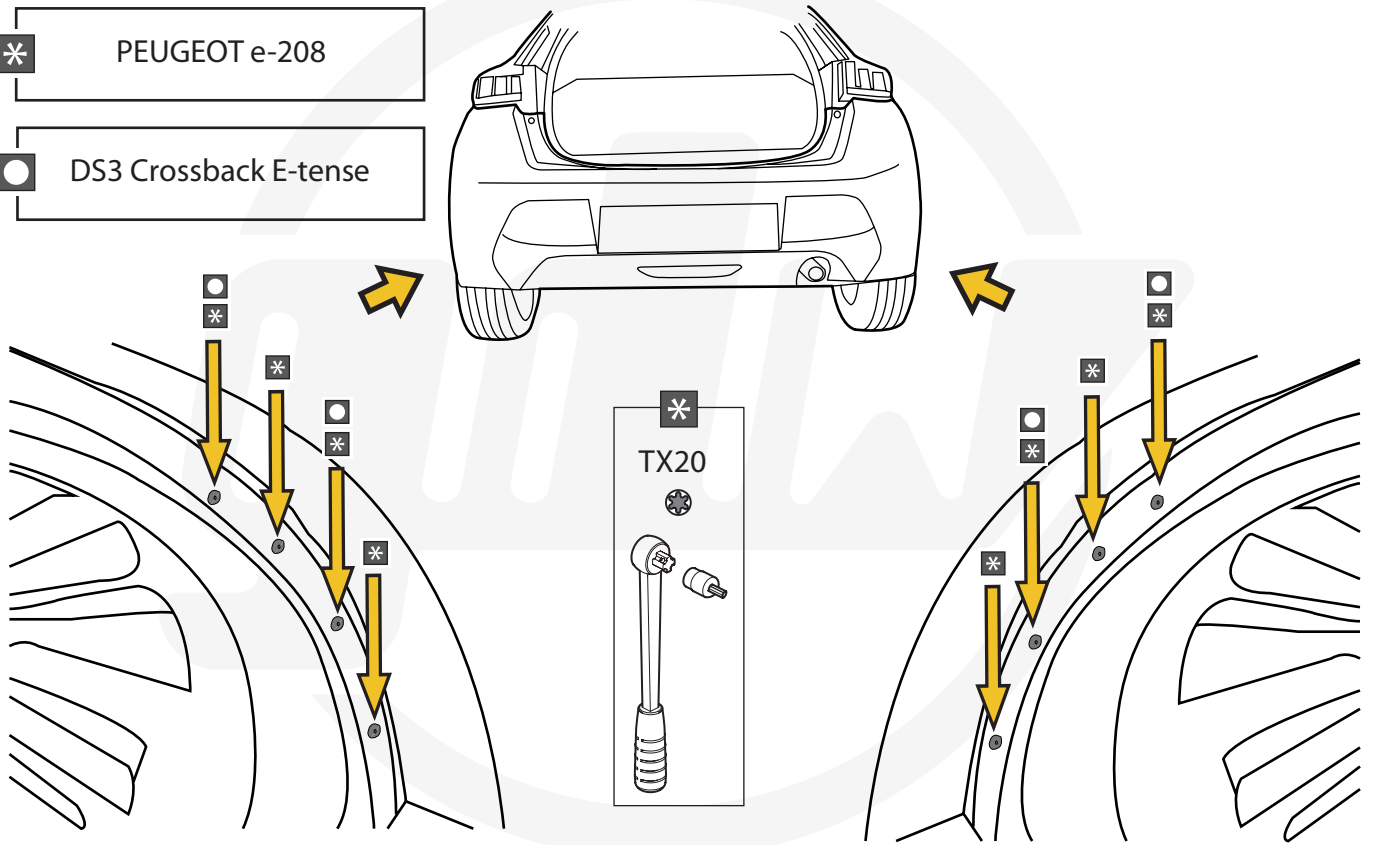

4

ONLY OPEL CORSA-e

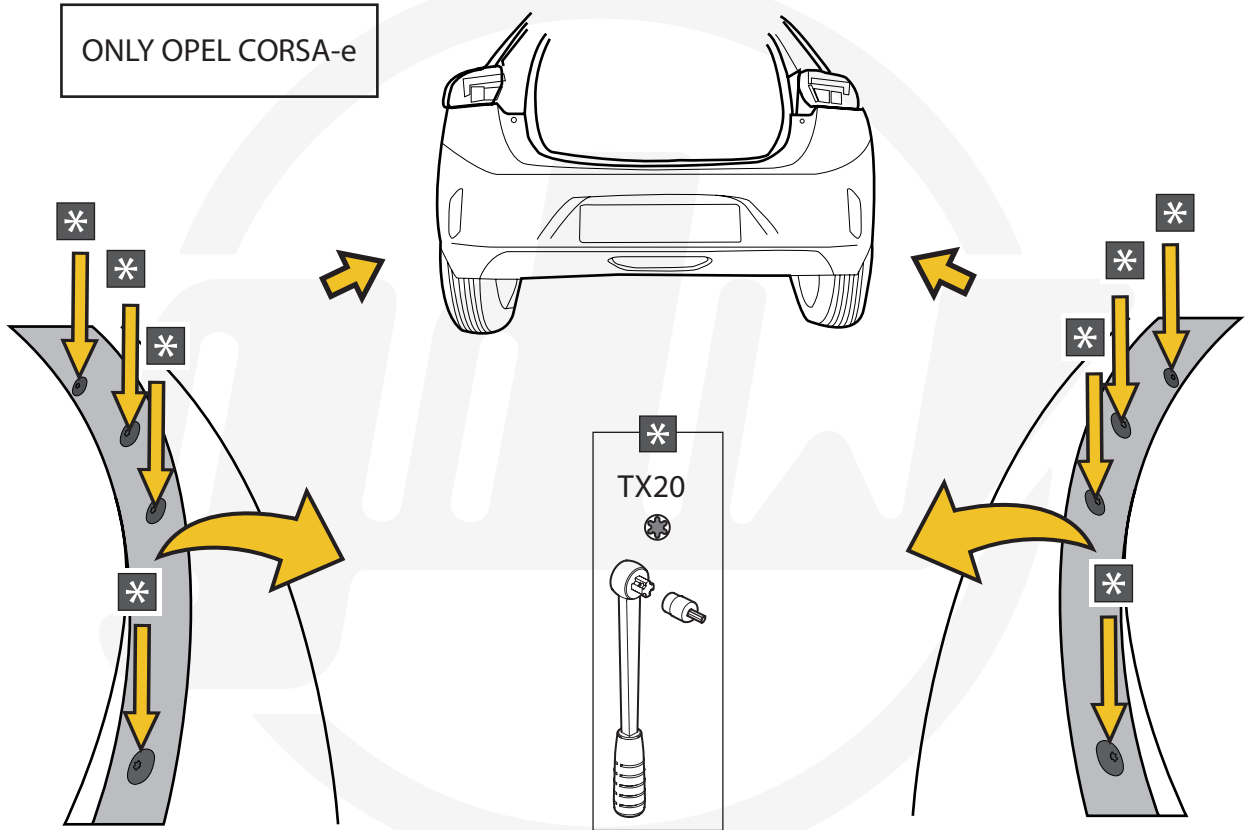

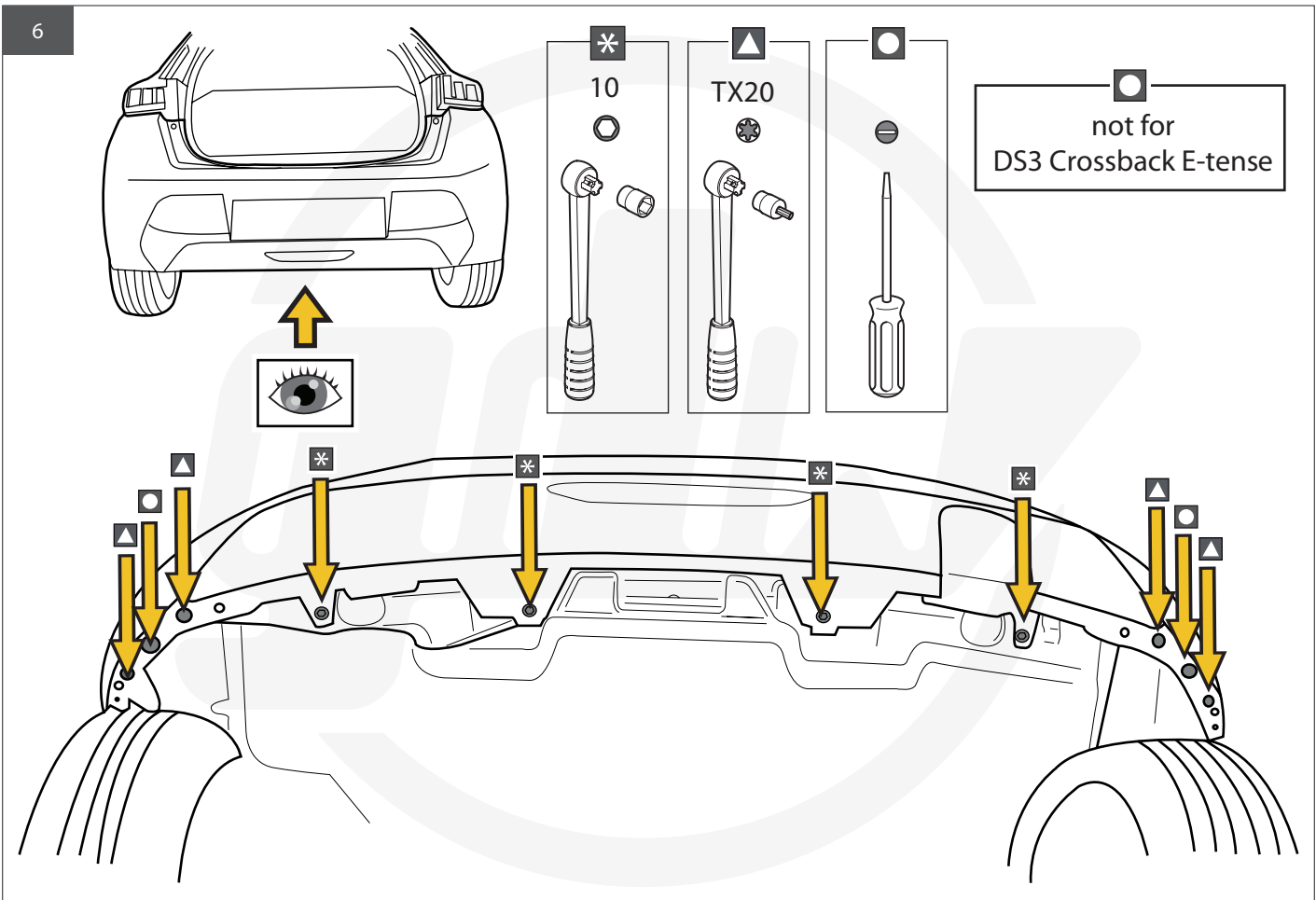
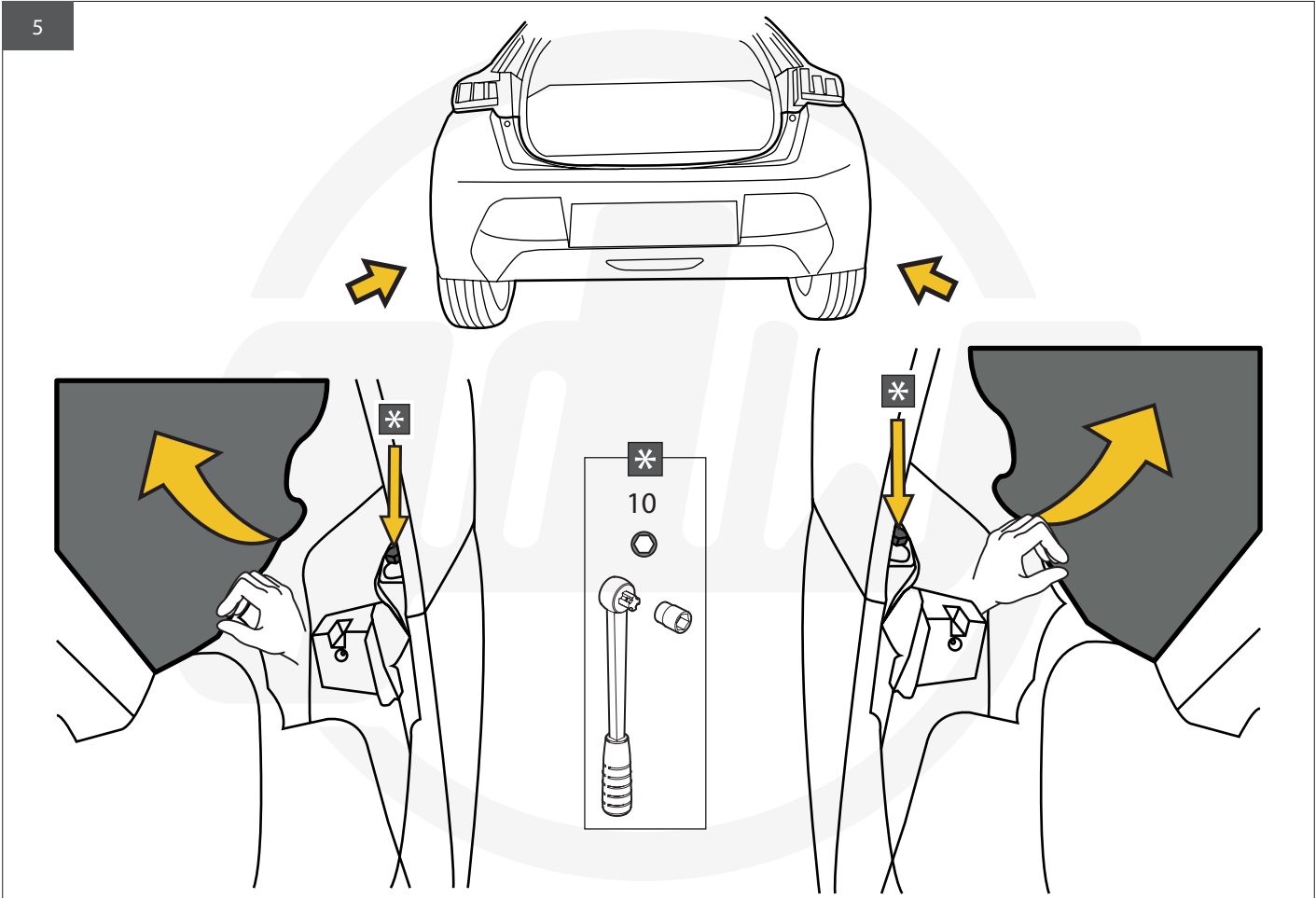

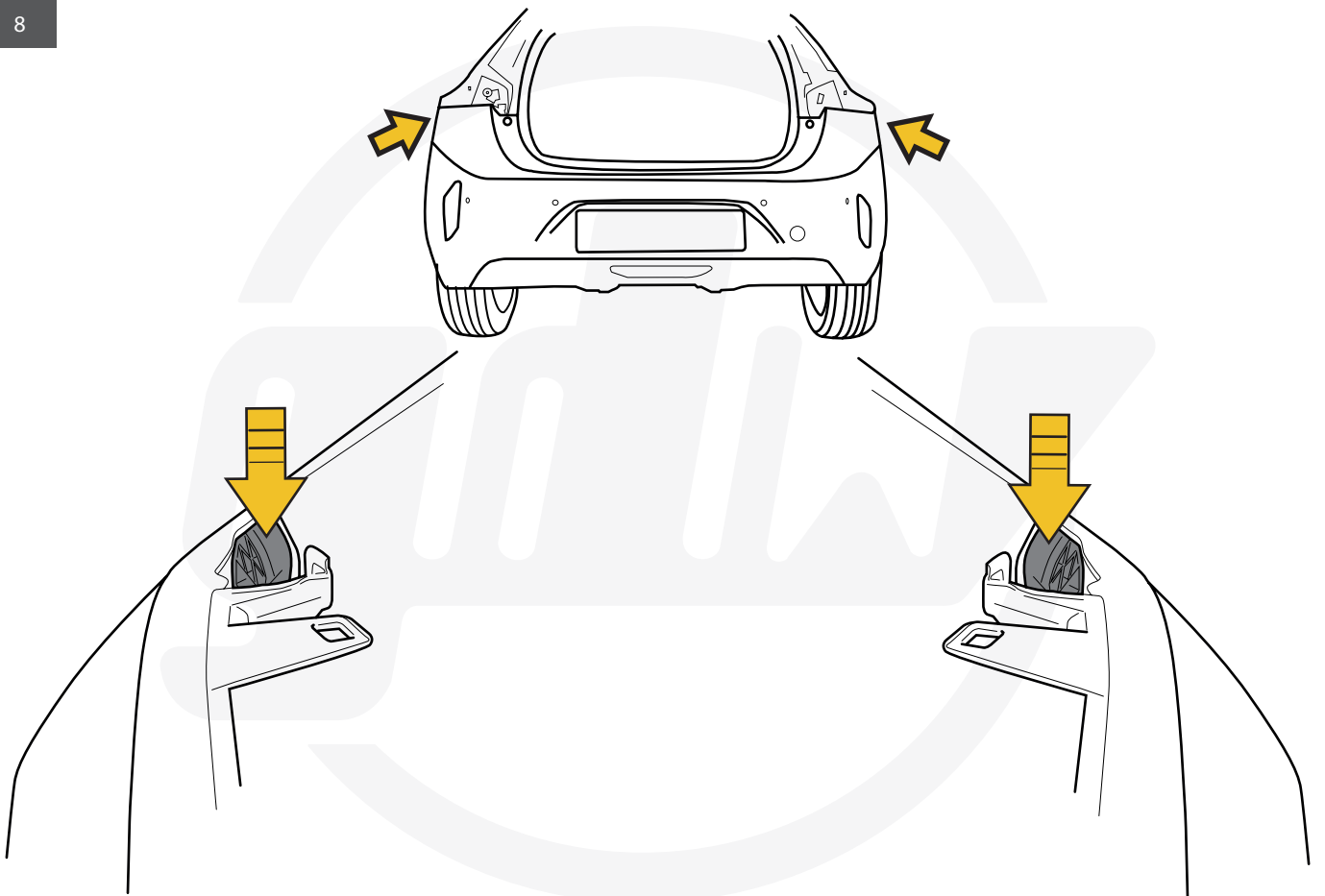
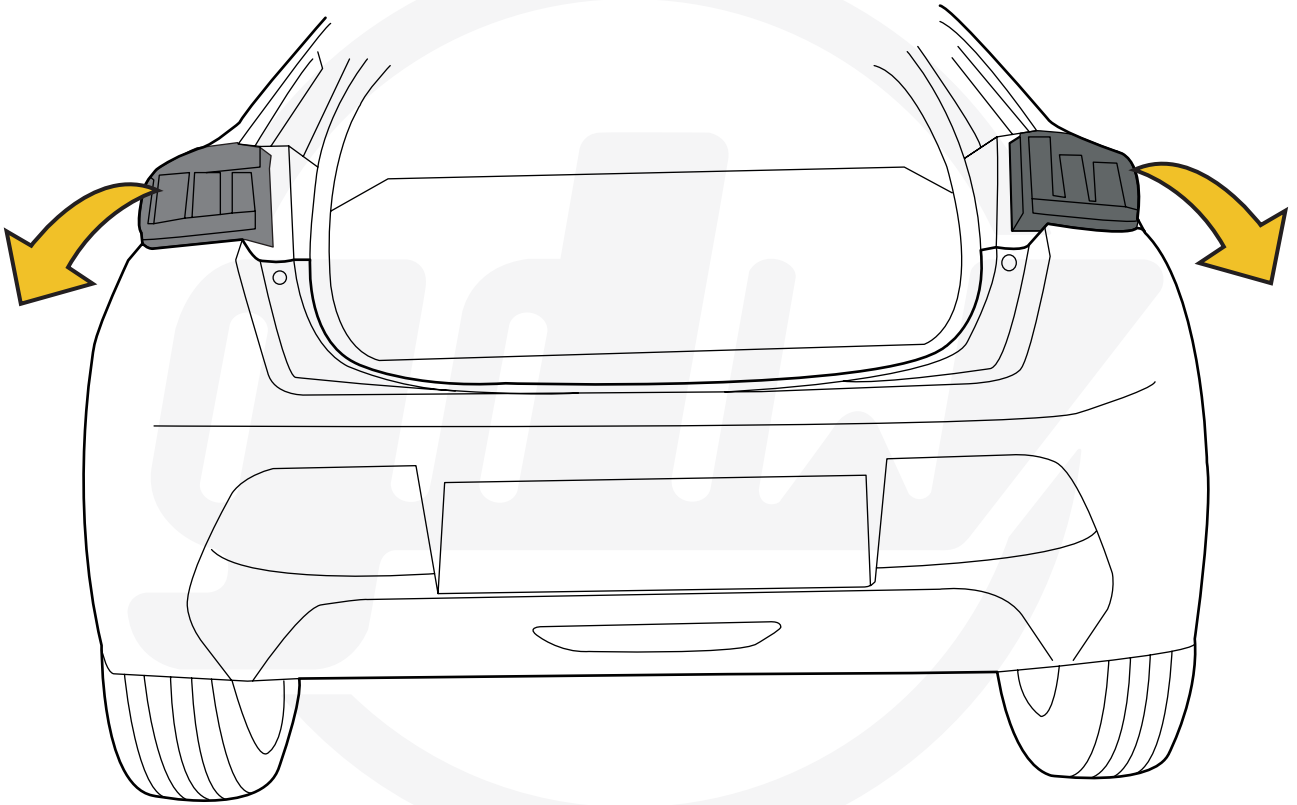

9

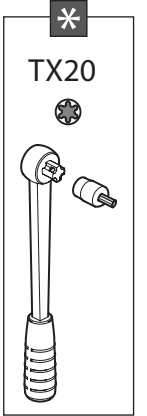
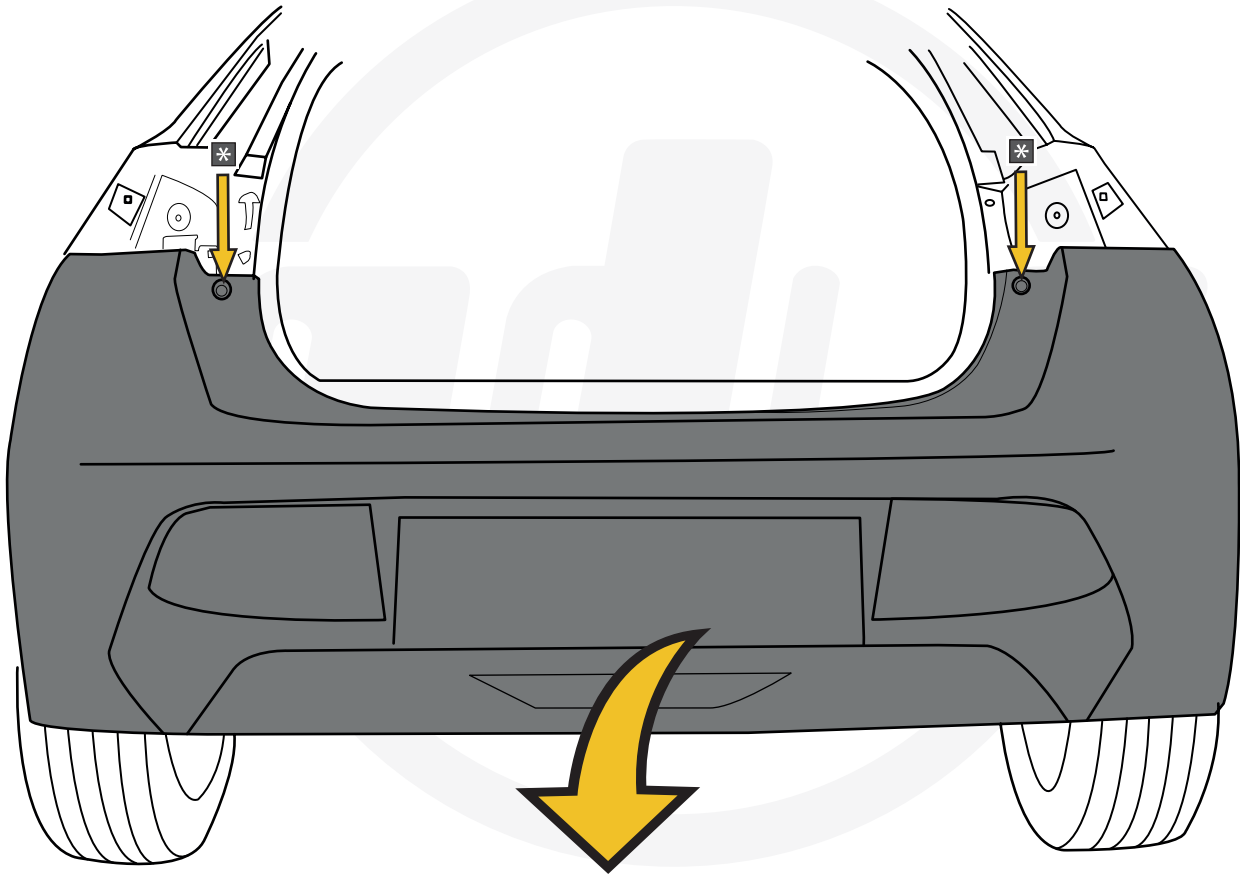

10

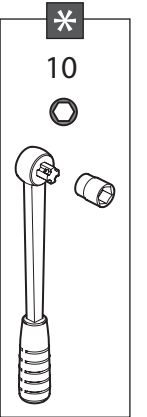
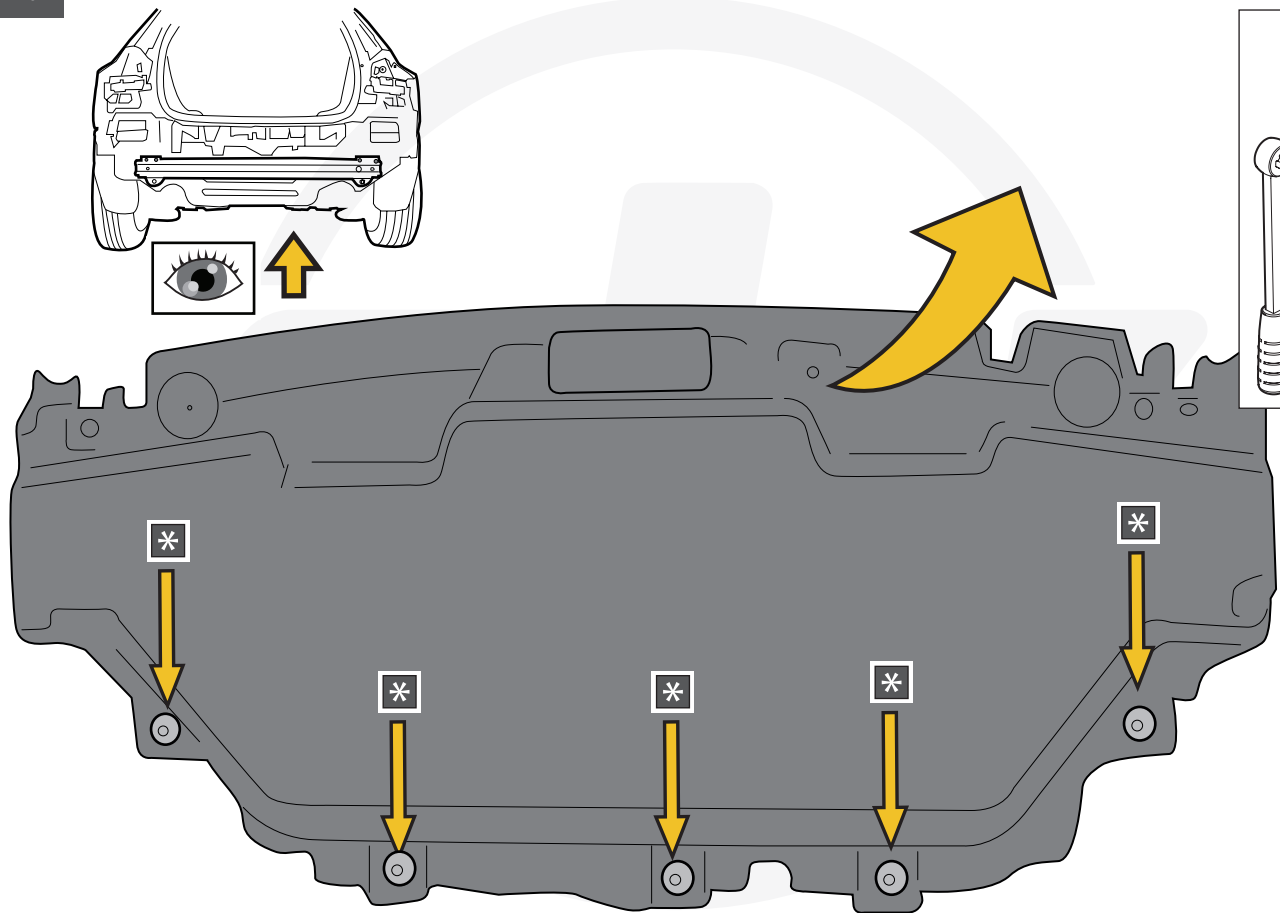

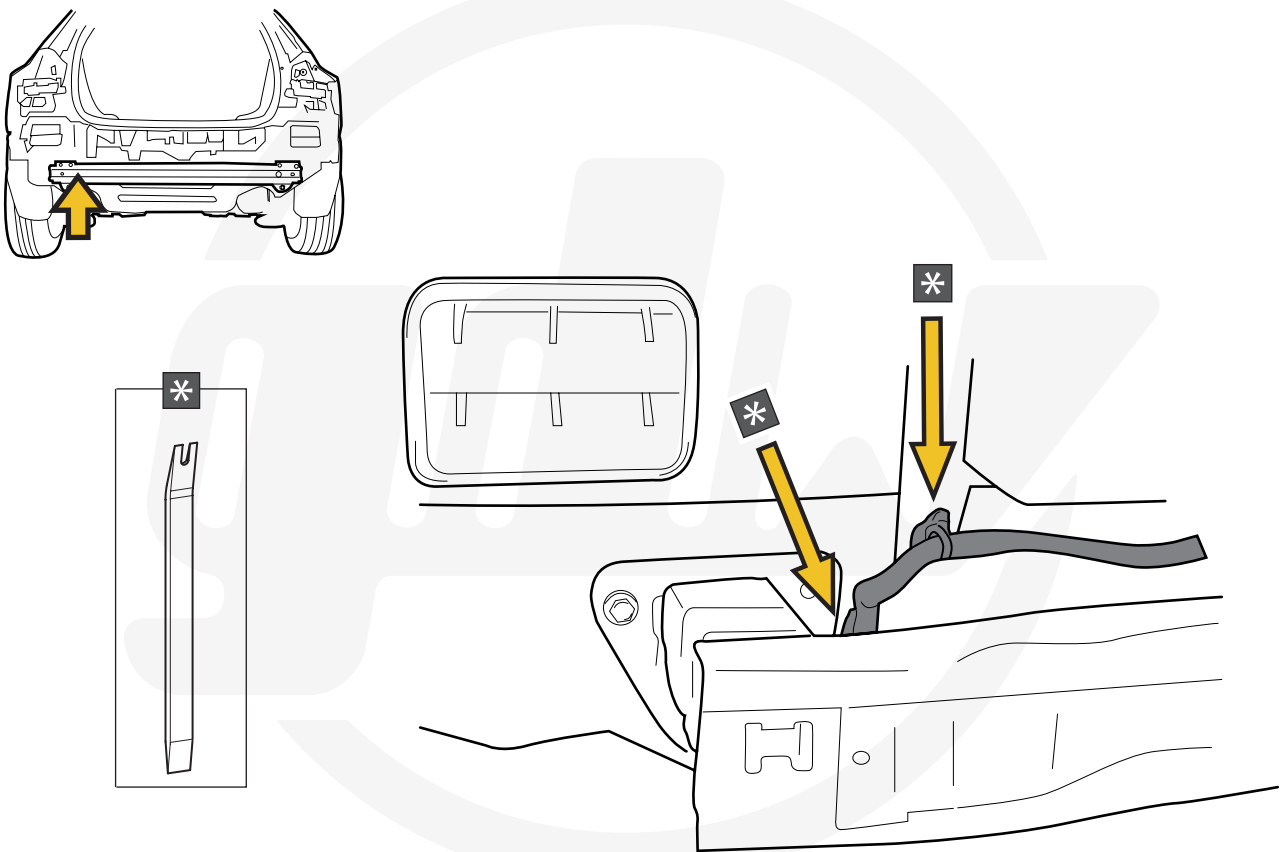
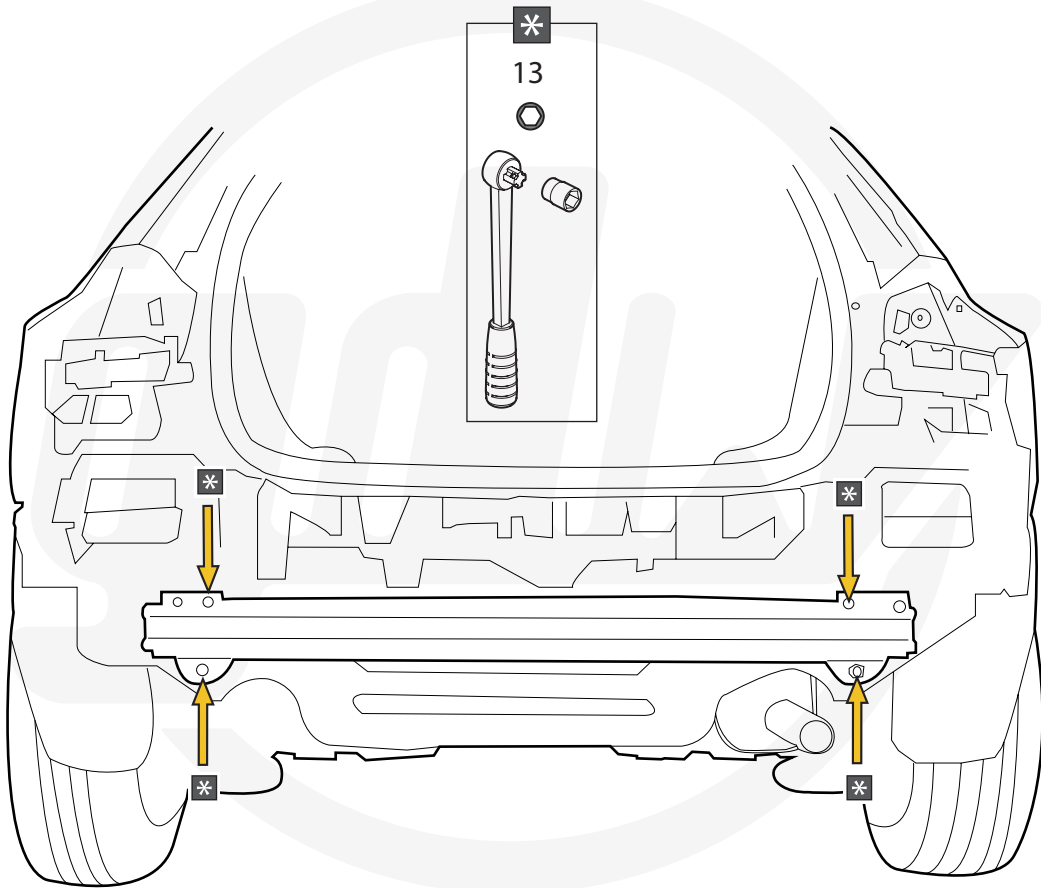

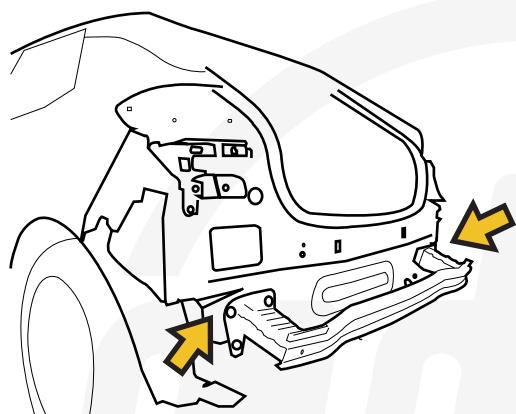

* Opel Mokka-e
DS3 Crossback E-tense

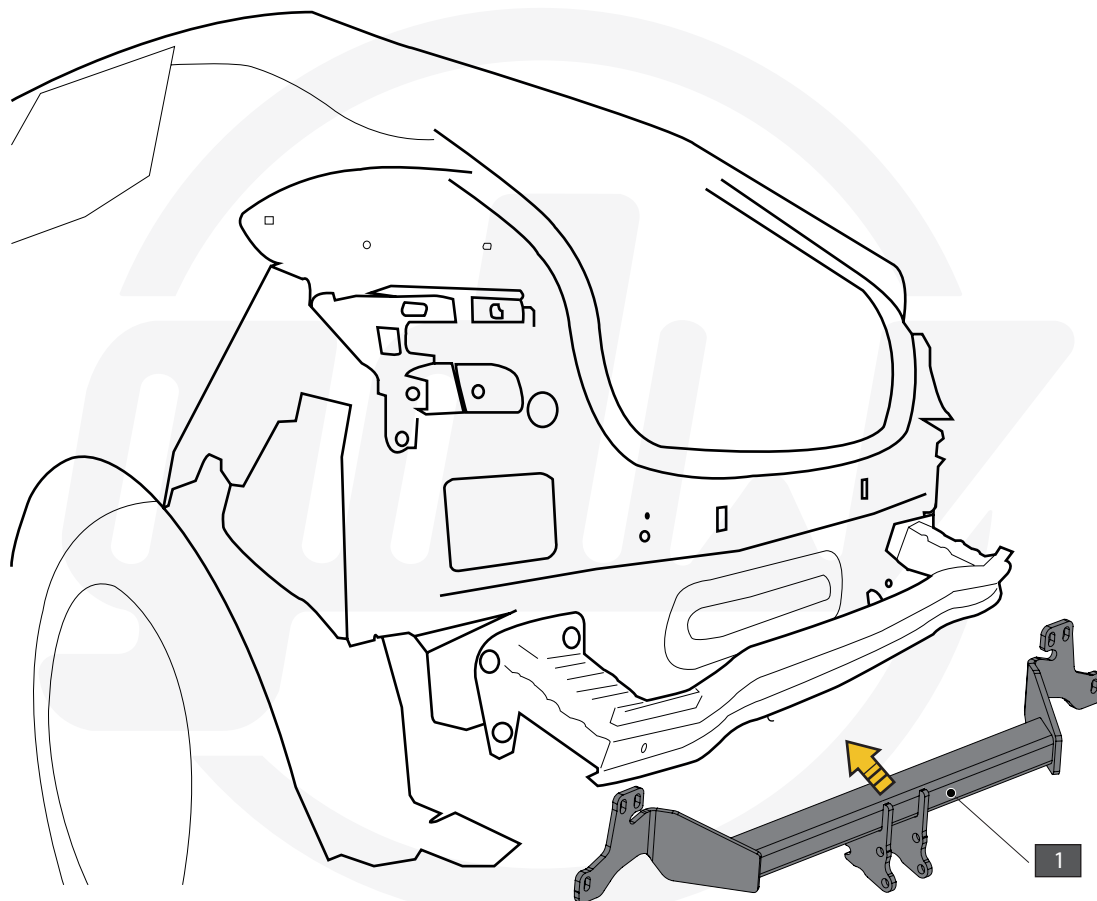
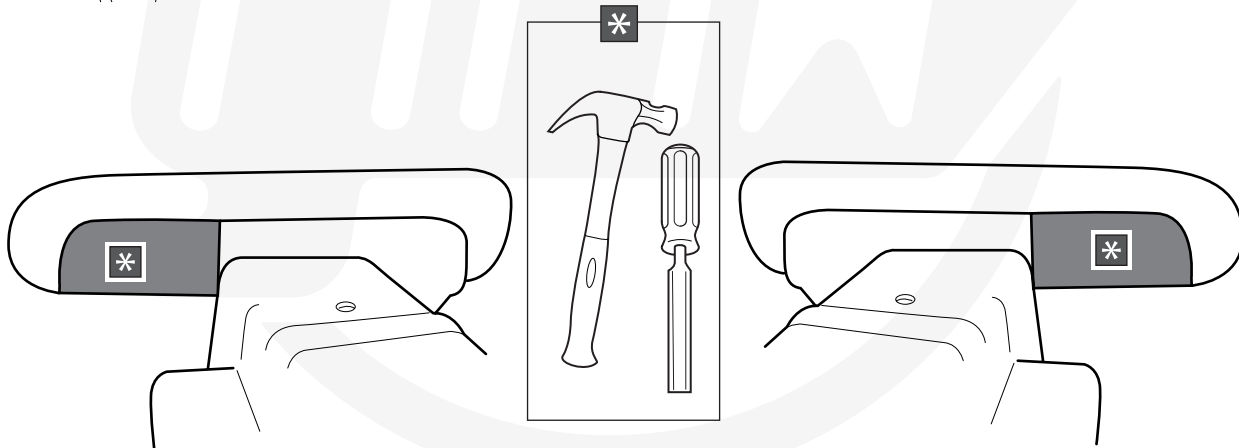

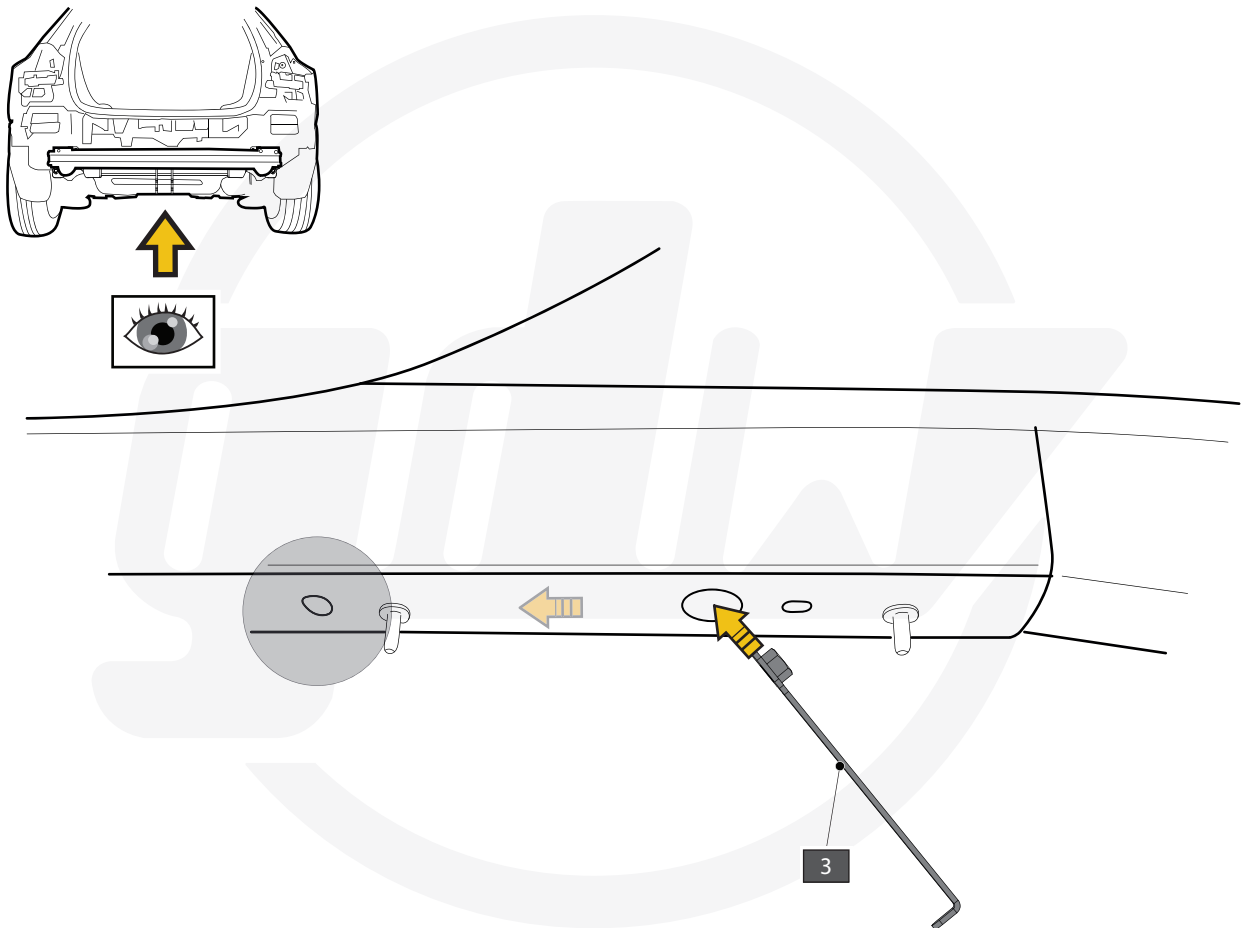
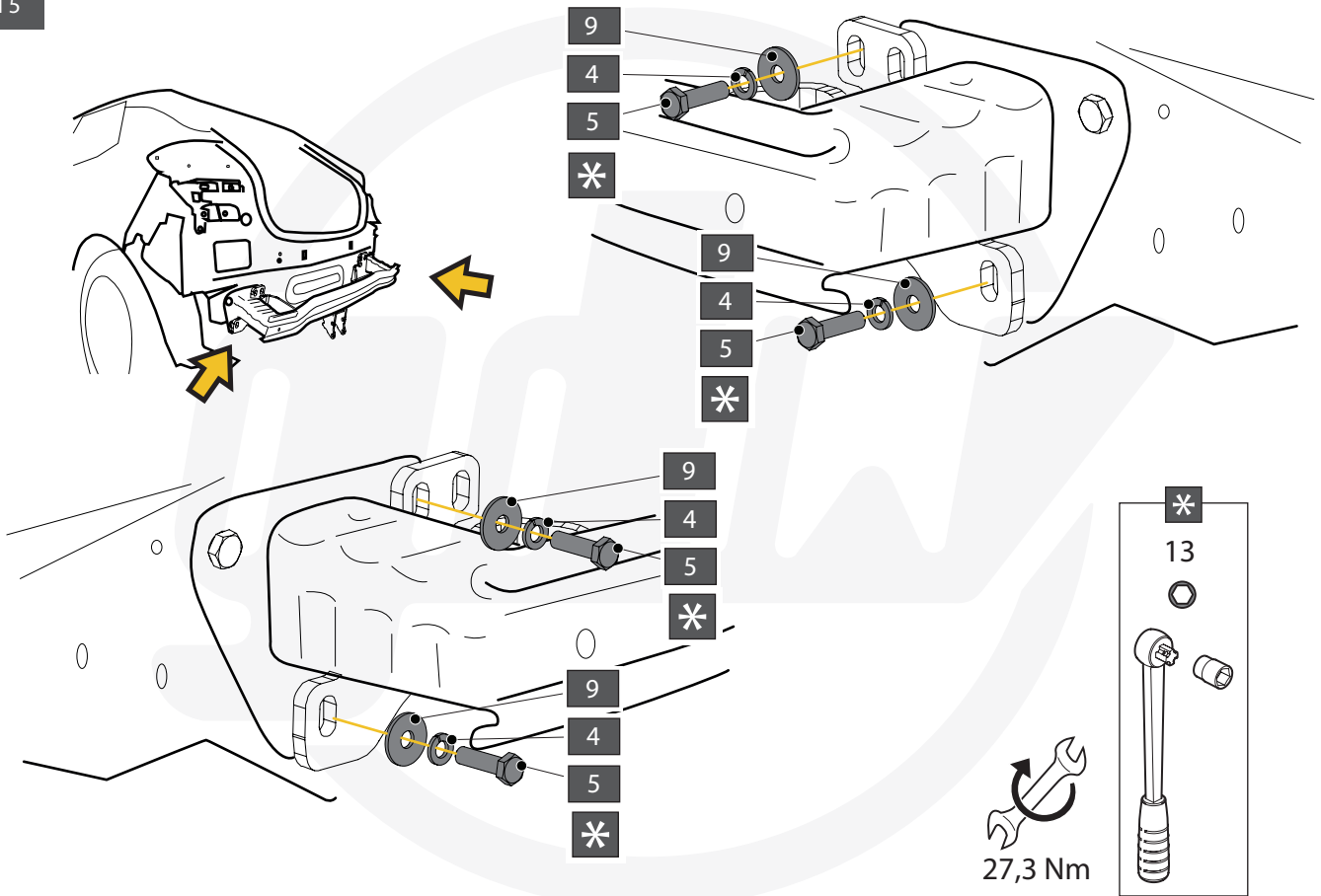

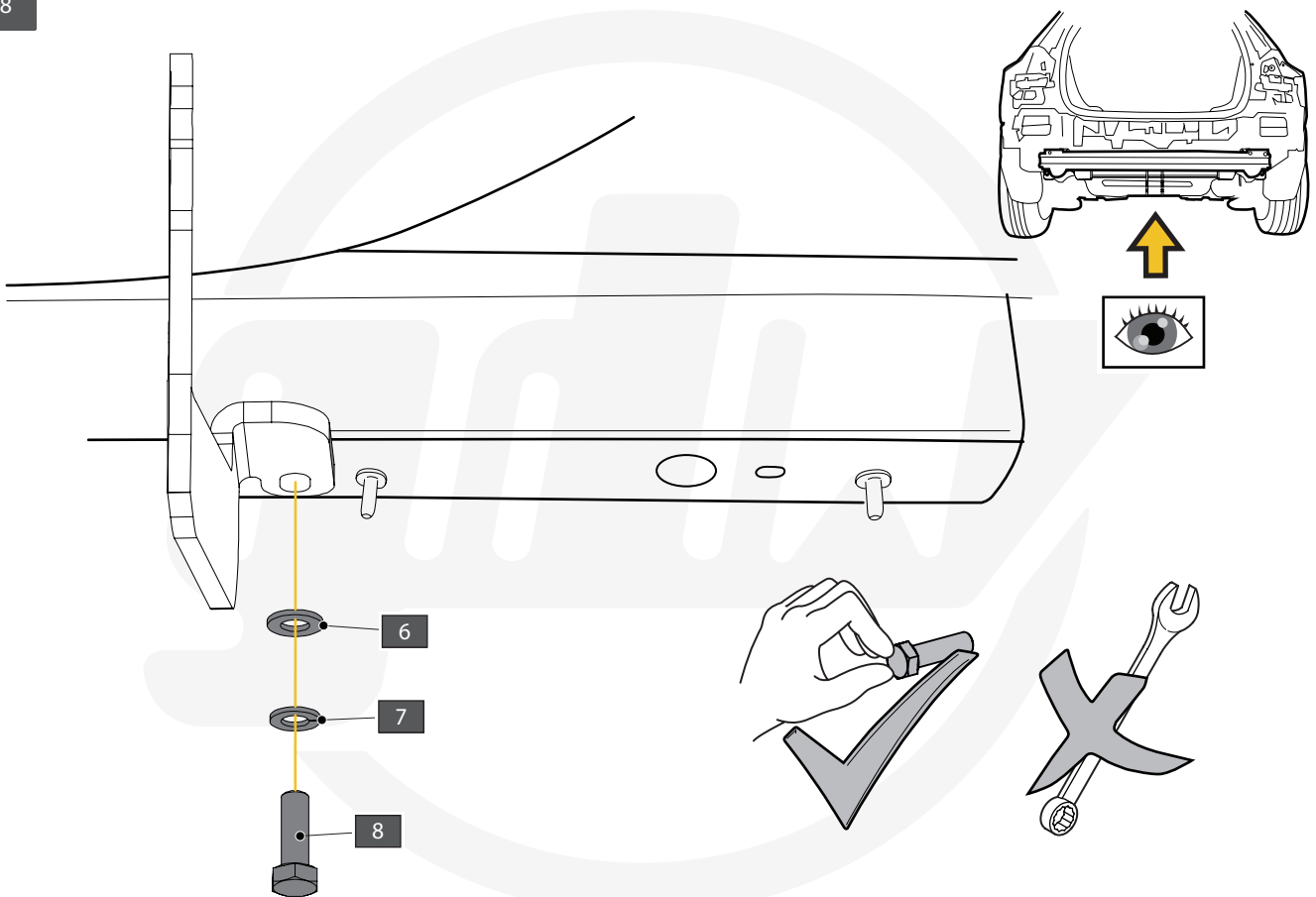
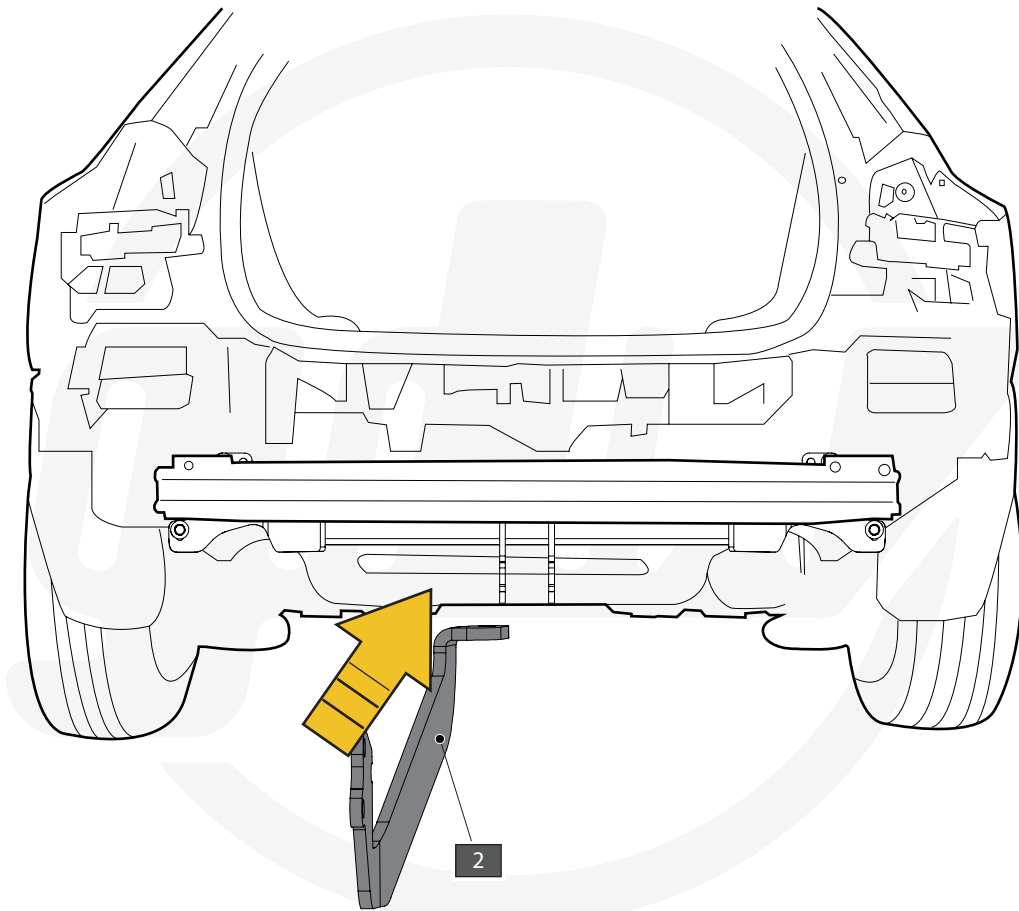

DS3 Crossback E-tense

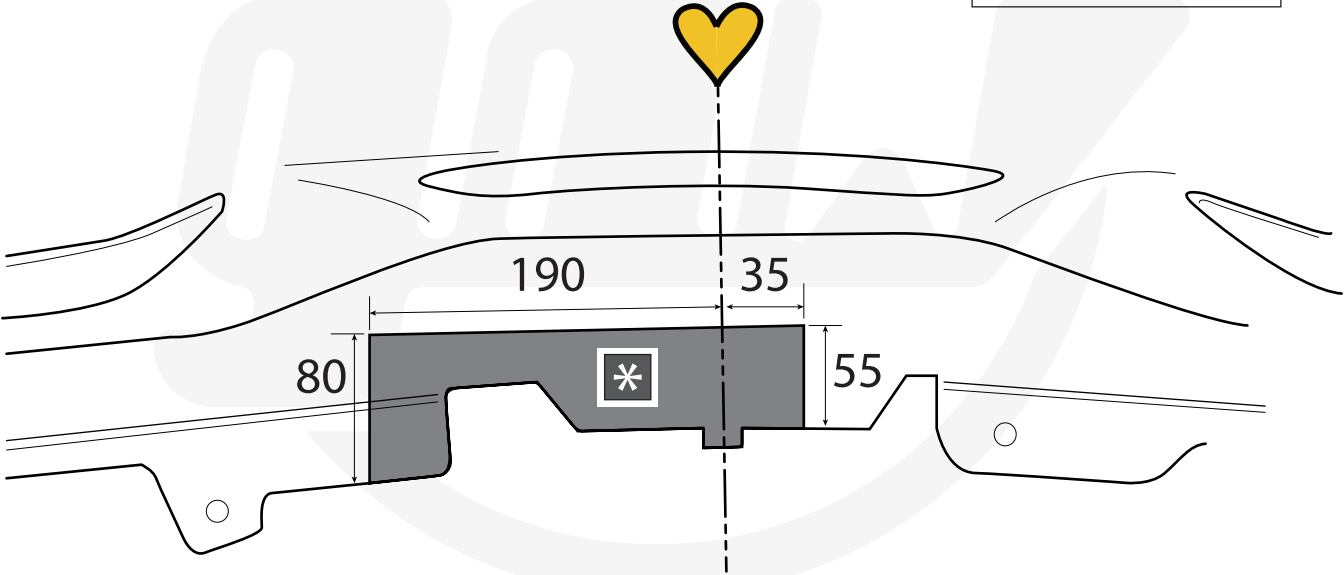
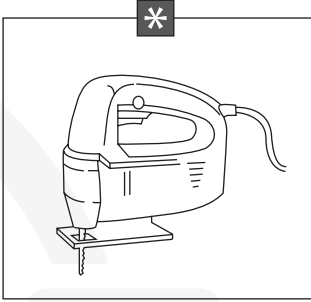

all other models

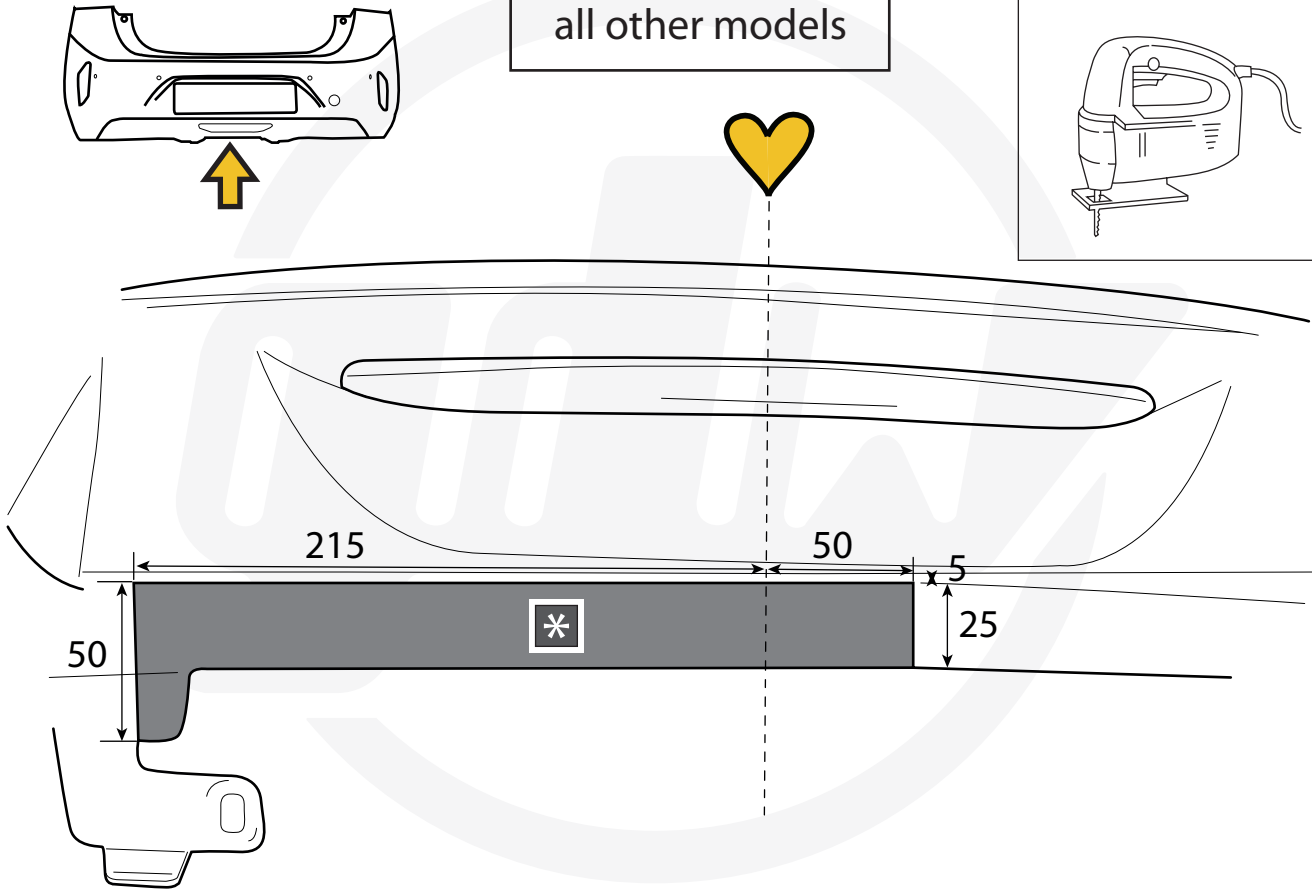
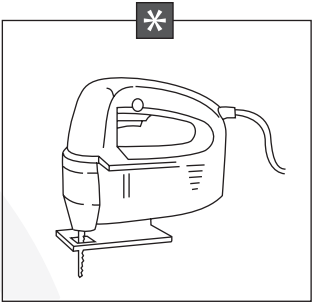

21

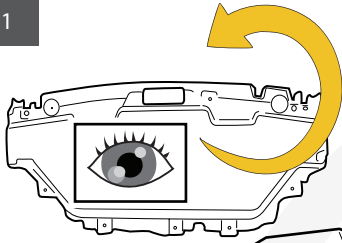

DS3 Crossback E-tense

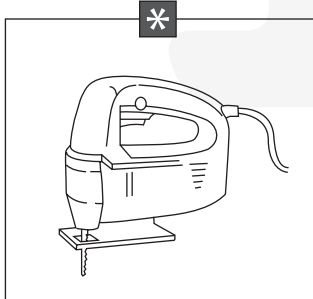
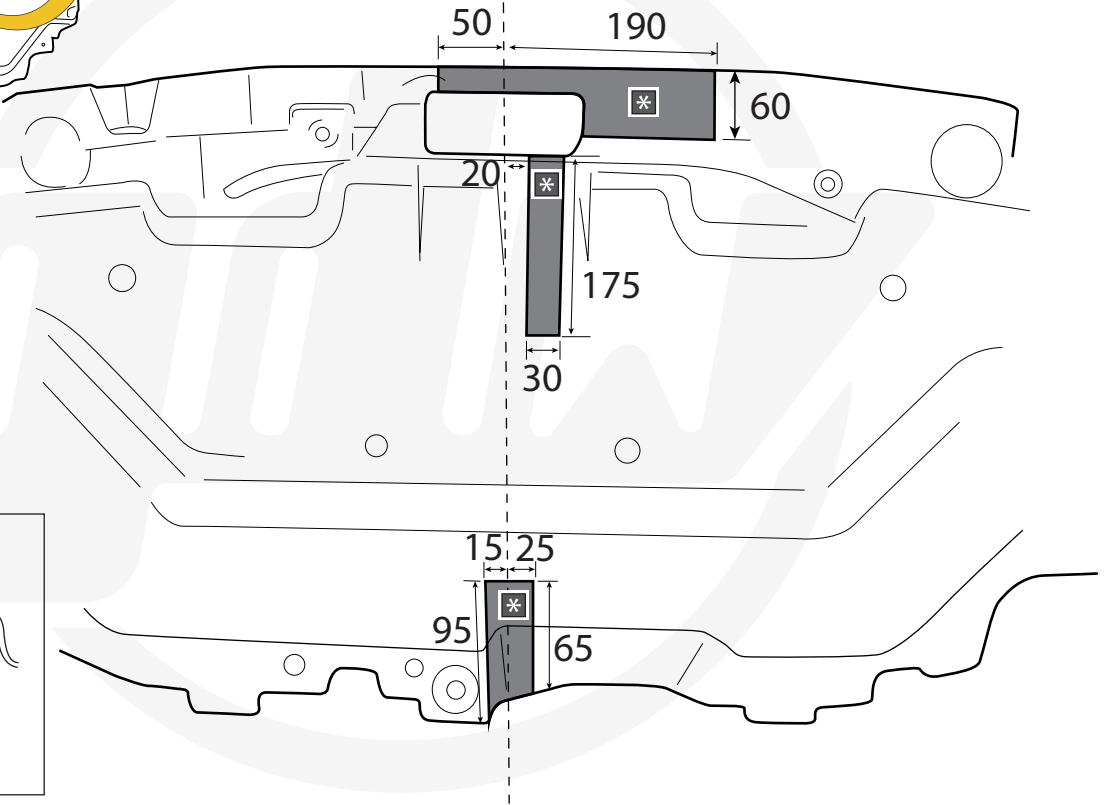

22

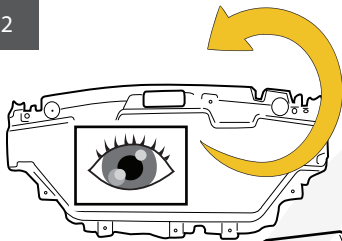

all other models

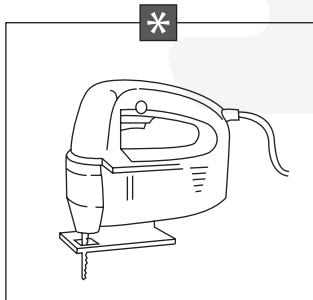
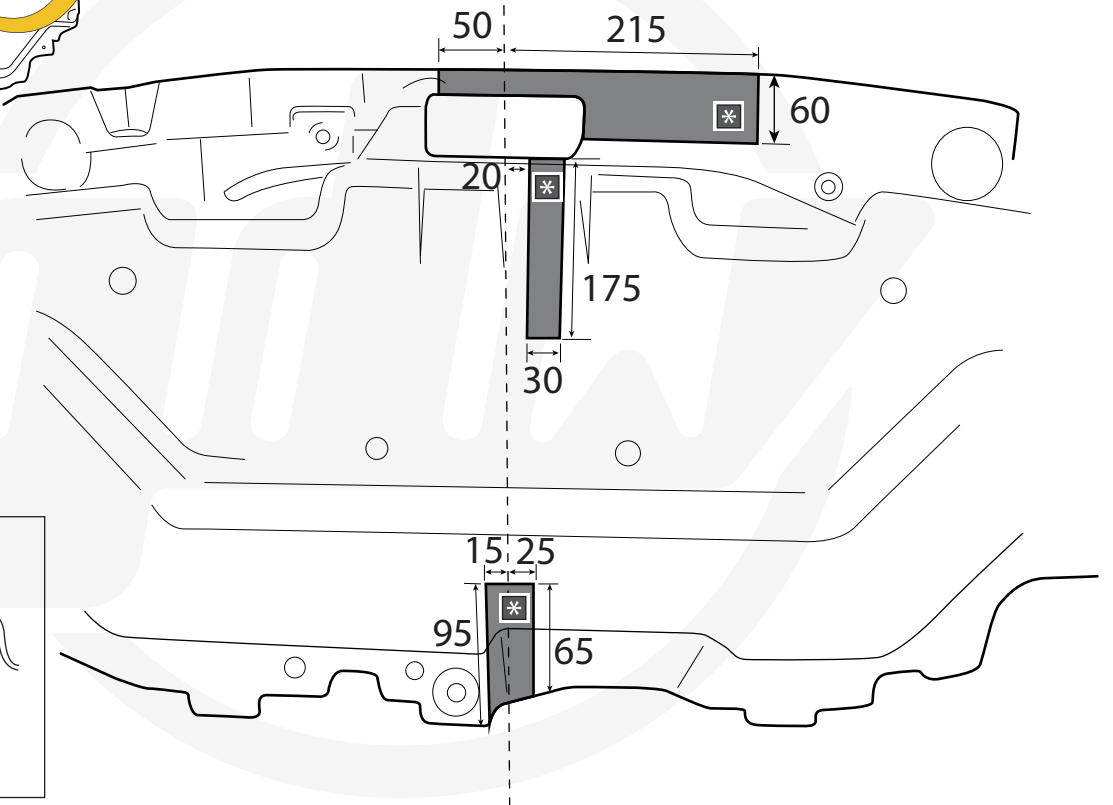

A		X1	GDW REF. 908.095
B		X1	DIN985-M6
C		X2	6,2 X 15,4 X 1,6 (NYLON)
D		X1	GDW REF. 718.16.002
E		X1	GDW REF. 718.16.003
F		X1	GDW REF. 908.094
G		X1	DIN933-M6 X 30

10

 2,0 Nm

A		X1	GDW REF. 912.003
B		X3	DIN931-M12X110-8.8
C		X3	DIN128A-M12
D		X6	DIN125A-M12
E		X3	DIN934-M12

19

 93,0 Nm

25

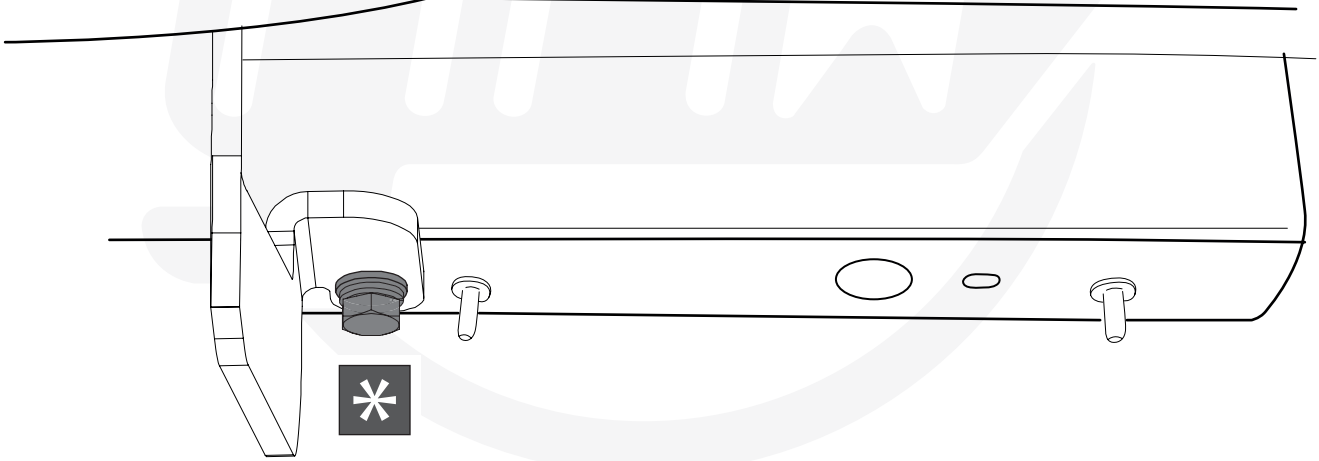
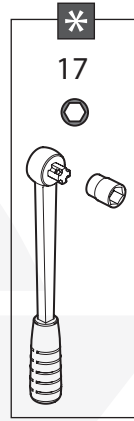
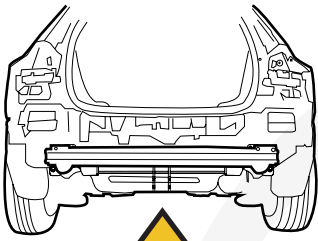

26

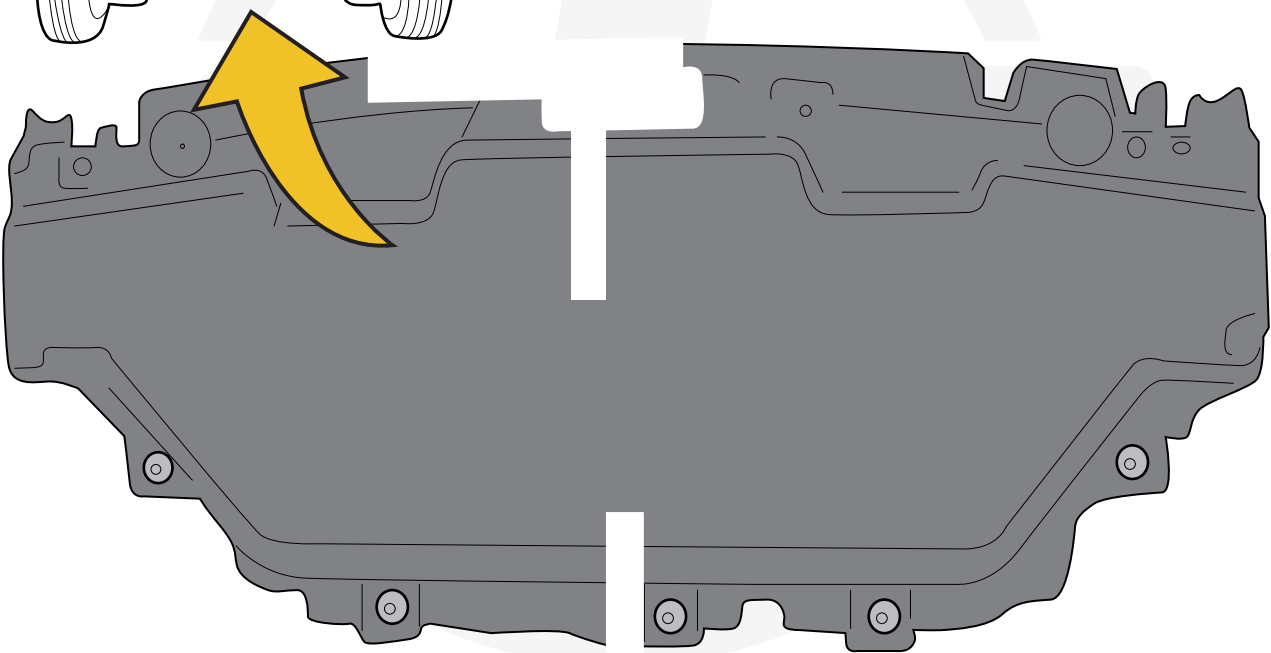
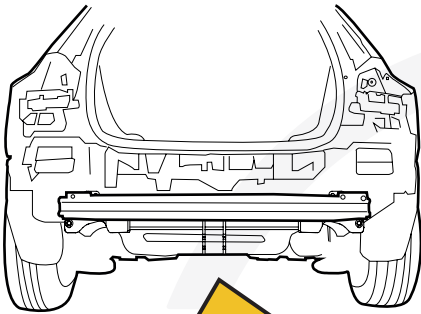

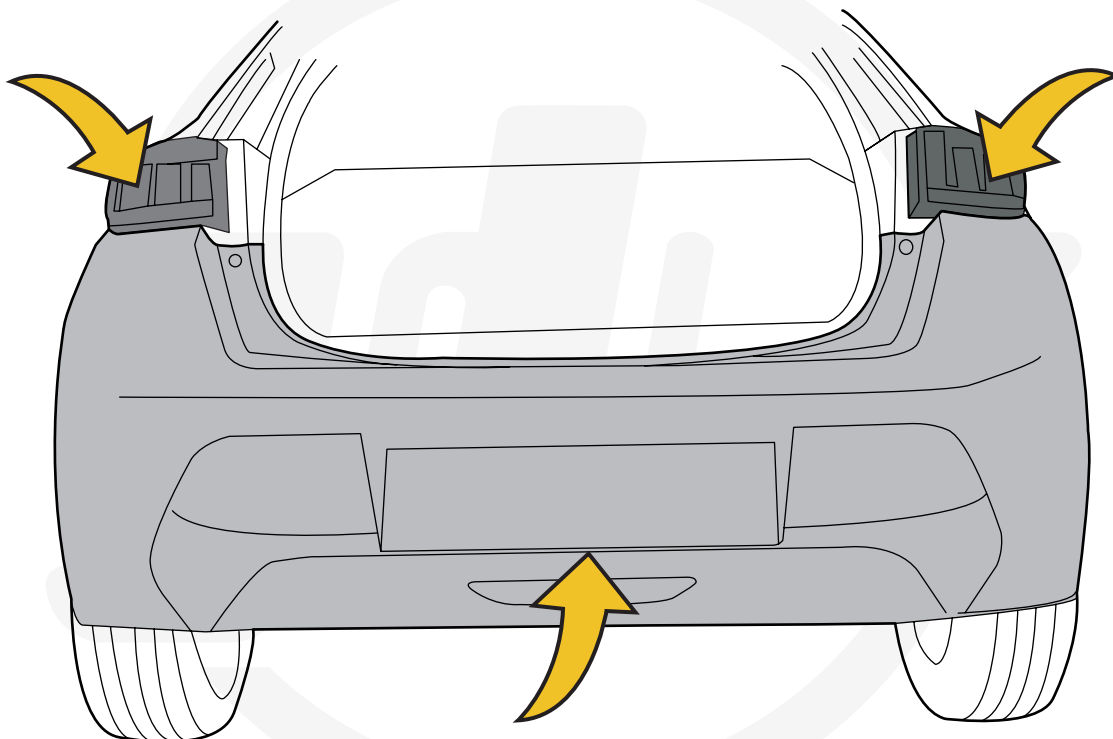

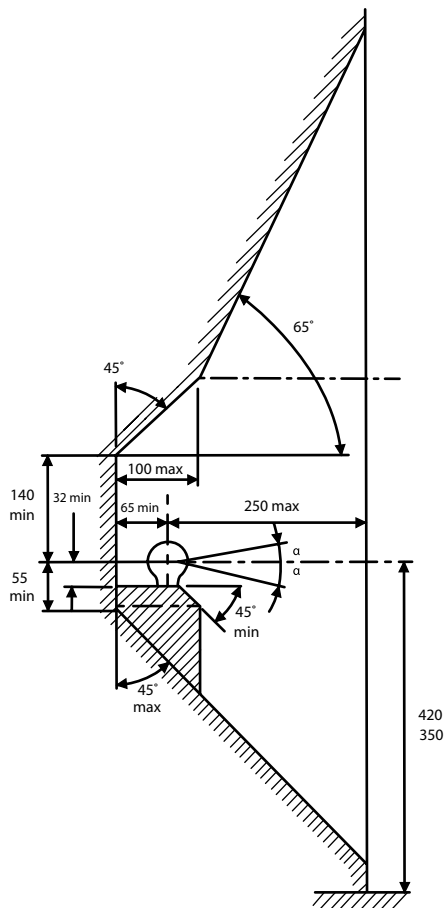

De tussenruimte conform bijlage VII, afbeelding 25 (a, b) van het reglement R55 UN/ECE moet in acht genomen worden. Deze voorschriften zijn niet van toepassing op terreinvoertuigen klasse G.

La zone de dégagement doit être garantie conformément à l'annexe VII, illustration 25 (a, b) de la règle R55 UN/ECE. Ces dispositions ne s'appliquent pas aux véhicules tout-terrain classe G.

The clearance specified in appendix VII, diagram 25 (a, b) of regulation R55 UN/ECE must be guaranteed. These requirements shall not apply to all-terrain vehicles class G.

Der Freiraum nach Anhang VII, Abbildung 25 (a, b) der Regulierung R55 UN/ECE ist zu gewährleisten. Diese Vorschriften gelten nicht für Geländefahrzeuge Klasse G.

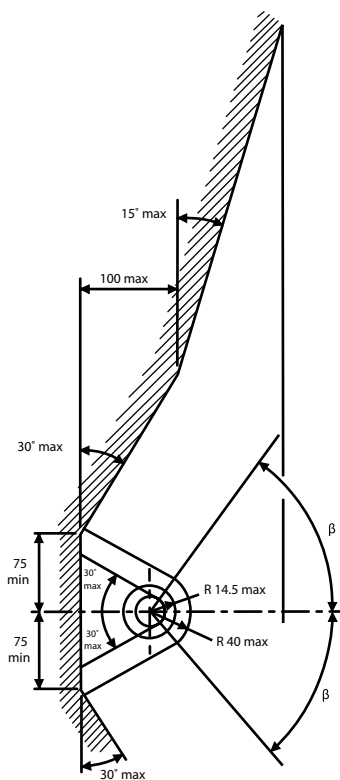

Bij toelaatbaar gewicht van het voertuig

Pour poids total en charge autorisé du véhicule

At laden weight of the vehicle

Bei zulässigem Gesamtgewicht des Fahrzeuges

Peso total admisible del vehículo

Ved tilladt samlet vægt for køretøjet

Peso totale ammissibile del veicolo